

Nikon

DIGITAL CAMERA

1 v3

Reference Manual

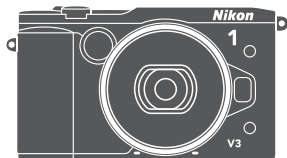

1

En

To get the most from your camera, please be sure to read all instructions thoroughly and keep them where they will be read by all who use the product.

Camera Settings

The explanations in this manual assume that default settings are used.

Symbols and Conventions

To make it easier to find the information you need, the following symbols and conventions are used:



This icon marks cautions; information that should be read before use to prevent damage to the camera.



This icon marks notes; information that should be read before using the camera.



This icon marks references to other pages in this manual.

The ▲, ▼, ◀, and ▶ symbols represent up, down, left, and right on the multi selector.

For Your Safety

Before using the camera for the first time, read the safety instructions in “For Your Safety” (□ xi–xiii).

1 v3

Getting the Most from Your Camera	 ii
Table of Contents	 iv
 Introduction	 1
 Taking and Viewing Photographs	 38
 Recording and Viewing Movies	 59
 P, S, A, and M Modes	 69
 Other Shooting Modes	 76
 More on Photography	 92
 Wi-Fi	 119
 More on Playback	 129
 Connections	 141
 The Playback Menu	 156
 The Shooting Menu	 167
 The Movie Menu	 189
 The Image Processing Menu	 195
 The Setup Menu	 209
 Technical Notes	 221

Getting the Most from Your Camera

Take photos with the shutter-release button.

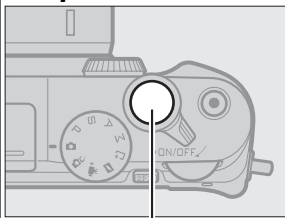

Shutter-release button

See page 8 for more information.

Shoot movies with the movie-record button.

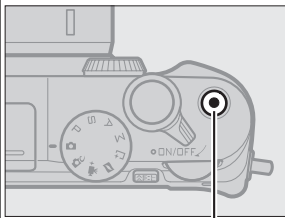

Movie-record button

Movies can be recorded by pressing the movie-record button in auto (📖 38), creative (📖 49), P, S, A, M (📖 69), and advanced movie (📖 59) modes.

Download pictures to a computer.

Install the supplied software (📖 141), and *copy* photos and movies to your computer using ViewNX 2 (📖 145).

View pictures in high definition.

Use an HDMI cable to *connect the camera to an HDTV* (📖 148).

Accessories

Expand your photographic horizons with a wide variety of interchangeable lenses and other accessories (☞ 221).



Lenses



Flash units



Mount adapters



Software for Nikon digital cameras
(available on CD)



GPS units



Remote controls



Electronic viewfinders

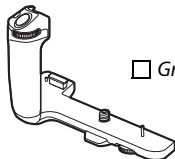

Grips

Table of Contents

Getting the Most from Your Camera	ii
Accessories	iii
For Your Safety.....	xi
Notices.....	xiv
Wireless	xix
Introduction	1
Before You Begin	1
Parts of the Camera.....	2
Using the Vari-Angle Monitor	15
Using the Touch Screen.....	17
First Steps.....	23
Attaching a Grip and Electronic Viewfinder	34
Taking and Viewing Photographs	38
Point-and-Shoot Photography (Auto Mode)	38
Viewing Photographs	41
Deleting Pictures	43
Live Image Control.....	47
Choosing a Creative Mode	49
Choosing a Mode That Matches the Subject or Situation.....	50
The Creative Palette	52
HDR	53
Easy Panorama	54
Selective Color.....	57
Cross Process	58

Recording and Viewing Movies	59
Recording Movies	59
Taking Photographs During Movie Recording	64
Viewing Movies	65
Deleting Movies	67
P, S, A, and M Modes	69
P Programmed Auto	70
S Shutter-Priority Auto	71
A Aperture-Priority Auto.....	72
M Manual	73
Other Shooting Modes	76
☒ Choosing the Moment (Best Moment Capture)	76
Choosing a Shot Manually (Active Selection).....	76
Choosing Your Moment (Slow View).....	80
Letting the Camera Choose the Moment (Smart Photo Selector).....	82
☑ Combining Photos with Brief Movie Vignettes (Motion Snapshot Mode)	87
Viewing Motion Snapshots	91
Deleting Motion Snapshots	91
More on Photography	92
Continuous Mode.....	92
Self-Timer Modes	94
Remote Control Photography	96
Focus Mode	99
Manual Focus	102
Exposure Compensation	104
The Built-in Flash.....	105

Optional Flash Units	109
Attaching Flash Units.....	109
Taking Pictures.....	110
The GP-N100 GPS Unit	113
Attaching the GP-N100.....	113
Setup Menu Options.....	114
Tap Shooting Options	116
Auto and Creative Modes.....	116
P, S, A, and M Modes.....	116
Advanced Movie Mode.....	117
Wi-Fi	119
<hr/>	
What Wi-Fi Can Do for You	119
Accessing the Camera	120
WPS (Android Only).....	121
PIN Entry (Android Only)	122
SSID (Android and iOS)	123
Uploading Pictures to a Smart Device	125
Uploading Photos One at a Time	125
Uploading Multiple Selected Photos.....	127
More on Playback	129
<hr/>	
Photo Information	129
Thumbnail Playback	133
Calendar Playback	134
Playback Zoom	135
Deleting Pictures	136
Deleting the Current Picture	136
The Playback Menu	136
Rating Pictures	137
Slide Shows	138

Connections	141
Installing the Supplied Software	141
System Requirements	143
Viewing and Editing Pictures on a Computer	145
Transferring Pictures	145
Viewing Pictures.....	147
Viewing Pictures on TV	148
High-Definition Devices	148
Printing Photographs	150
Connecting the Printer	150
Printing Pictures One at a Time	151
Printing Multiple Pictures	153
Creating a DPOF Print Order: Print Set.....	155
The Playback Menu	156
Selecting Multiple Images	158
Image Review	159
Rotate Tall	159
Protect	159
Rating	160
D-Lighting	160
Resize	161
Crop	162
Edit Movie	163
Combine 4-Second Movies	165
Combine NMS Movies	166

The Shooting Menu **167**

Exposure Mode	170
Image Quality	171
Image Size	172
Active Selection	174
Number of Shots Saved	175
Movie Before/After	175
File Format	176
Soft	176
Toy Camera Effect	177
Metering	177
Auto Distortion Control	178
Color Space	178
Active D-Lighting	179
Long Exposure NR	180
Interval Timer Shooting	181
Optical VR	183
Electronic VR	184
AF-Area Mode	185
Built-in AF Assist	186
Flash Control	187
Flash Compensation	188

The Movie Menu **189**

Slow Motion	191
Frame Size/Frame Rate	192
Movie Sound Options	193
Auto Image Capture	194

The Image Processing Menu	195
White Balance	196
Fine-Tuning White Balance	197
Preset Manual	198
ISO Sensitivity	201
Picture Control.....	202
Modifying Picture Controls	202
Custom Picture Control.....	206
Edit/Save	206
Load from/Save to Card	207
High ISO Noise Reduction	208
The Setup Menu	209
Format Memory Card	211
Slot Empty Release Lock	211
Display.....	211
Display Brightness	211
Viewfinder Brightness.....	212
Grid Display.....	212
Playback Highlight Display	212
Silent Photography.....	212
Sound Settings	212
Auto Power Off	213
Remote on Duration	213
Assign AE/AF-L Button	214
Autoexposure Lock.....	214
Focus Lock.....	216
Flicker Reduction.....	217
Reset File Numbering	218
Time Zone and Date	218
Auto Image Rotation	219
Pixel Mapping.....	220

Optional Accessories	221
Approved Memory Cards	224
Attaching a Power Connector and AC Adapter	225
Storage and Cleaning	227
Storage.....	227
Cleaning.....	227
Caring for the Camera and Battery: Cautions	228
Available Settings.....	232
Defaults	235
Memory Card Capacity	236
Troubleshooting	239
Battery/Display.....	239
Shooting (All Modes)	240
Shooting (P, S, A, and M Modes)	241
Movies	242
Tap Shooting Options	242
Playback.....	242
Wi-Fi (Wireless Networks).....	243
Miscellaneous	243
Error Messages	244
Specifications	247
Nikon 1 V3 Digital Camera	247
Battery Life.....	265
Index	266

For Your Safety

To prevent damage to your Nikon product or injury to yourself or to others, read the following safety precautions in their entirety before using this equipment. Keep these safety instructions where all those who use the product will read them.

The consequences that could result from failure to observe the precautions listed in this section are indicated by the following symbol:



This icon marks warnings. To prevent possible injury, read all warnings before using this Nikon product.

■ ■ ■ WARNINGS

- ⚠ **Keep the sun out of the frame.** Keep the sun well out of the frame when shooting backlit subjects. Sunlight focused into the camera when the sun is in or close to the frame could cause a fire.
- ⚠ **Do not look at the sun through the viewfinder.** Viewing the sun or other strong light source through the viewfinder could cause permanent visual impairment.
- ⚠ **Turn off immediately in the event of malfunction.** Should you notice smoke or an unusual smell coming from the equipment or AC adapter (available separately), unplug the AC adapter and remove the battery immediately, taking care to avoid burns. Continued operation could result in injury. After removing the battery, take the equipment to a Nikon-authorized service center for inspection.
- ⚠ **Do not use in the presence of flammable gas.** Do not use electronic equipment in the presence of flammable gas, as this could result in explosion or fire.
- ⚠ **Keep dry.** Do not immerse in or expose to water or handle with wet hands. Failure to keep the product dry could result in damage to the product, fire, or electric shock, while handling the product with wet hands could result in electric shock.
- ⚠ **Do not disassemble.** Touching the product's internal parts could result in injury. In the event of malfunction, the product should be repaired only by a qualified technician. Should the product break open as the result of a fall or other accident, remove the battery and/or AC adapter and then take the product to a Nikon-authorized service center for inspection.
- ⚠ **Keep out of reach of children.** Failure to observe this precaution could result in injury. In addition, note that small parts constitute a choking hazard. Should a child swallow any part of this equipment, consult a physician immediately.

- ⚠ Do not place the strap around the neck of an infant or child.** Placing the camera strap around the neck of an infant or child could result in strangulation.
- ⚠ Follow the instructions of airline and hospital personnel.** This camera transmits radio frequencies that could interfere with medical equipment or aircraft navigation. Disable the wireless network feature before boarding an aircraft, and turn the camera off during take off and landing. In medical facilities, follow staff instructions regarding the use of wireless devices.
- ⚠ Do not remain in contact with the camera, battery, or charger for extended periods while the devices are on or in use.** Parts of the device become hot. Leaving the device in direct contact with the skin for extended periods may result in low-temperature burns.
- ⚠ Do not leave the product where it will be exposed to extremely high temperatures, such as in an enclosed automobile or in direct sunlight.** Failure to observe this precaution could cause damage or fire.
- ⚠ Do not aim the flash at the operator of a motor vehicle.** Failure to observe this precaution could result in accidents.
- ⚠ Observe caution when using a flash.**
- Using the camera with the flash in close contact with the skin or other objects could cause burns.
 - Using a flash close to the subject's eyes could cause temporary visual impairment. The flash should be no less than one meter (3 ft 4 in.) from the subject. Particular care should be observed when photographing infants.
- ⚠ Avoid contact with liquid crystal.** Should the display break, care should be taken to avoid injury due to broken glass and to prevent the liquid crystal from the display touching the skin or entering the eyes or mouth.
- ⚠ Do not carry tripods with a lens or camera attached.** You could trip or accidentally strike others, resulting in injury.
- ⚠ Observe proper precautions when handling batteries.** Batteries may leak or explode if improperly handled. Observe the following precautions when handling batteries for use in this product:
- Use only batteries approved for use in this equipment.
 - Do not short or disassemble the battery.
 - Be sure the product is off before replacing the battery. If you are using an AC adapter, be sure it is unplugged.
 - Do not attempt to insert the battery upside down or backwards.

- Do not expose the battery to flame or to excessive heat.
 - Do not immerse in or expose to water.
 - Replace the terminal cover when transporting the battery. Do not transport or store the battery with metal objects such as necklaces or hairpins.
 - Batteries are prone to leakage when fully discharged. To avoid damage to the product, be sure to remove the battery when no charge remains.
 - When the battery is not in use, attach the terminal cover and store in a cool, dry place.
 - The battery may be hot immediately after use or when the product has been used on battery power for an extended period. Before removing the battery turn the camera off and allow the battery to cool.
 - Discontinue use immediately should you notice any changes in the battery, such as discoloration or deformation.
- Dust on or near the metal parts of the plug should be removed with a dry cloth. Continued use could result in fire.
 - Do not go near the charger during thunderstorms. Failure to observe this precaution could result in electric shock.
 - Do not handle the plug or charger with wet hands. Failure to observe this precaution could result in injury or product malfunction due to fire or electric shock.
 - Do not use with travel converters or adapters designed to convert from one voltage to another or with DC-to-AC inverters. Failure to observe this precaution could damage the product or cause overheating or fire.

⚠ Use appropriate cables. When connecting cables to the input and output jacks, use only the cables provided or sold by Nikon for the purpose to maintain compliance with product regulations.

⚠ CD-ROMs: CD-ROMs containing software or manuals should not be played back on audio CD equipment. Playing CD-ROMs on an audio CD player could cause hearing loss or damage the equipment.

⚠ Observe proper precautions when handling the charger:

- Keep dry. Failure to observe this precaution could result in injury or product malfunction due to fire or electric shock.
- Do not short the charger terminals. Failure to observe this precaution could result in overheating and damage to the charger.

Notices

- No part of the manuals included with this product may be reproduced, transmitted, transcribed, stored in a retrieval system, or translated into any language in any form, by any means, without Nikon's prior written permission.
- Nikon reserves the right to change the specifications of the hardware and software described in these manuals at any time and without prior notice.
- Nikon will not be held liable for any damages resulting from the use of this product.
- While every effort has been made to ensure that the information in these manuals is accurate and complete, we would appreciate it were you to bring any errors or omissions to the attention of the Nikon representative in your area (address provided separately).

Notice for Customers in Canada

CAN ICES-3 B / NMB-3 B

Notice for Customers in Europe

CAUTION: RISK OF EXPLOSION IF BATTERY IS REPLACED BY AN INCORRECT TYPE. DISPOSE OF USED BATTERIES ACCORDING TO THE INSTRUCTIONS.

This symbol indicates that electrical and electronic equipment is to be collected separately.



The following apply only to users in European countries:

- This product is designated for separate collection at an appropriate collection point. Do not dispose of as household waste.
- Separate collection and recycling helps conserve natural resources and prevent negative consequences for human health and the environment that might result from incorrect disposal.
- For more information, contact the retailer or the local authorities in charge of waste management.

This symbol on the battery indicates that the battery is to be collected separately.



The following apply only to users in European countries:

- All batteries, whether marked with this symbol or not, are designated for separate collection at an appropriate collection point. Do not dispose of as household waste.
- For more information, contact the retailer or the local authorities in charge of waste management.

Notice for Customers in the U.S.A.

The Battery Charger

IMPORTANT SAFETY INSTRUCTIONS—SAVE THESE INSTRUCTIONS

DANGER—TO REDUCE THE RISK OF FIRE OR ELECTRIC SHOCK, CAREFULLY FOLLOW THESE INSTRUCTIONS

For connection to a supply not in the U.S.A., use an attachment plug adapter of the proper configuration for the power outlet if needed. This power unit is intended to be correctly oriented in a vertical or floor mount position.

Federal Communications Commission (FCC) Radio Frequency Interference Statement

This equipment has been tested and found to comply with the limits for a Class B digital device, pursuant to Part 15 of the FCC rules. These limits are designed to provide reasonable protection against harmful interference in a residential installation. This equipment generates, uses, and can radiate radio frequency energy and, if not installed and used in accordance with the instructions, may cause harmful interference to radio communications. However, there is no guarantee that interference will not occur in a particular installation. If this equipment does cause harmful interference to radio or television reception, which can be determined by turning the equipment off and on, the user is encouraged to try to correct the interference by one or more of the following measures:

- Reorient or relocate the receiving antenna.
- Increase the separation between the equipment and receiver.
- Connect the equipment into an outlet on a circuit different from that to which the receiver is connected.
- Consult the dealer or an experienced radio/television technician for help.



Nikon
1 V3

CAUTIONS

Modifications

The FCC requires the user be notified that any changes or modifications made to this device that are not expressly approved by Nikon Corporation may void the user's authority to operate the equipment.

Interface Cables

Use the interface cables sold or provided by Nikon for your equipment. Using other interface cables may exceed the limits of Class B Part 15 of the FCC rules.

Notice for Customers in the State of California

WARNING: Handling the cord on this product may expose you to lead, a chemical known to the State of California to cause birth defects or other reproductive harm. *Wash hands after handling.*

Nikon Inc., 1300 Walt Whitman Road,
Melville, New York 11747-3064, U.S.A.
Tel.: 631-547-4200

Notice Concerning Prohibition of Copying or Reproduction

Note that simply being in possession of material that has been digitally copied or reproduced by means of a scanner, digital camera, or other device may be punishable by law.

- **Items prohibited by law from being copied or reproduced**
- **Cautions on certain copies and reproductions**

Do not copy or reproduce paper money, coins, securities, government bonds, or local government bonds, even if such copies or reproductions are stamped "Sample."

The copying or reproduction of paper money, coins, or securities which are circulated in a foreign country is prohibited.

Unless the prior permission of the government has been obtained, the copying or reproduction of unused postage stamps or post cards issued by the government is prohibited.

The copying or reproduction of stamps issued by the government and of certified documents stipulated by law is prohibited.

The government has issued cautions on copies or reproductions of securities issued by private companies (shares, bills, checks, gift certificates, etc.), commuter passes, or coupon tickets, except when a minimum of necessary copies are to be provided for business use by a company. Also, do not copy or reproduce passports issued by the government, licenses issued by public agencies and private groups, ID cards, and tickets, such as passes and meal coupons.

- **Comply with copyright notices**

The copying or reproduction of copyrighted creative works such as books, music, paintings, woodcuts, prints, maps, drawings, movies, and photographs is governed by national and international copyright laws. Do not use this product for the purpose of making illegal copies or to infringe copyright laws.

AVC Patent Portfolio License

THIS PRODUCT IS LICENSED UNDER THE AVC PATENT PORTFOLIO LICENSE FOR THE PERSONAL AND NON-COMMERCIAL USE OF A CONSUMER TO (i) ENCODE VIDEO IN COMPLIANCE WITH THE AVC STANDARD ("AVC VIDEO") AND/OR (ii) DECODE AVC VIDEO THAT WAS ENCODED BY A CONSUMER ENGAGED IN A PERSONAL AND NON-COMMERCIAL ACTIVITY AND/OR WAS OBTAINED FROM A VIDEO PROVIDER LICENSED TO PROVIDE AVC VIDEO. NO LICENSE IS GRANTED OR SHALL BE IMPLIED FOR ANY OTHER USE. ADDITIONAL INFORMATION MAY BE OBTAINED FROM MPEG LA, L.L.C. SEE <http://www.mpegla.com>

Disposing of Data Storage Devices

Please note that deleting images or formatting memory cards or other data storage devices does not completely erase the original image data. Deleted files can sometimes be recovered from discarded storage devices using commercially available software, potentially resulting in the malicious use of personal image data. Ensuring the privacy of such data is the user's responsibility.

Before discarding a data storage device or transferring ownership to another person, erase all data using commercial deletion software, or format the device and then completely refill it with images containing no private information (for example, pictures of empty sky). Wi-Fi settings can be reset to default values by selecting **Wi-Fi > Wi-Fi connection type > Reset Wi-Fi settings** in the setup menu (☰ 124). Care should be taken to avoid injury when physically destroying data storage devices.

Temperature Warnings

The camera may become warm to the touch during use; this is normal and does not indicate a malfunction. At high ambient temperatures, after extended periods of continuous use, or after several photographs have been taken in quick succession, a temperature warning may be displayed, following which the camera will turn off automatically to minimize damage to its internal circuits. Wait for the camera to cool before resuming use.

Use Only Nikon Brand Electronic Accessories

Nikon cameras are designed to the highest standards and include complex electronic circuitry. Only Nikon brand electronic accessories (including chargers, batteries, AC adapters, and lens accessories) certified by Nikon specifically for use with this Nikon digital camera are engineered and proven to operate within the operational and safety requirements of this electronic circuitry.

The use of non-Nikon electronic accessories could damage the camera and may void your Nikon warranty. The use of third-party rechargeable Li-ion batteries not bearing the Nikon holographic seal shown at right could interfere with normal operation of the camera or result in the batteries overheating, igniting, rupturing, or leaking.



For more information about Nikon brand accessories, contact a local authorized Nikon dealer.

Use Only Nikon Brand Accessories

Only Nikon brand accessories certified by Nikon specifically for use with your Nikon digital camera are engineered and proven to operate within its operational and safety requirements. THE USE OF NON-NIKON ACCESSORIES COULD DAMAGE YOUR CAMERA AND MAY VOID YOUR NIKON WARRANTY.

Servicing the Camera and Accessories

The camera is a precision device and requires regular servicing. Nikon recommends that the camera be inspected by the original retailer or a Nikon-authorized service representative once every one to two years, and that it be serviced once every three to five years (note that fees apply to these services). Frequent inspection and servicing are particularly recommended if the camera is used professionally. Any accessories regularly used with the camera, such as lenses, should be included when the camera is inspected or serviced.

Before Taking Important Pictures

Before taking pictures on important occasions (such as at weddings or before taking the camera on a trip), take a test shot to ensure that the camera is functioning normally. Nikon will not be held liable for damages or lost profits that may result from product malfunction.

Life-Long Learning

As part of Nikon's "Life-Long Learning" commitment to ongoing product support and education, continually-updated information is available on-line at the following sites:

- **For users in the U.S.A.:** <http://www.nikonusa.com/>
- **For users in Europe and Africa:** <http://www.europe-nikon.com/support/>
- **For users in Asia, Oceania, and the Middle East:** <http://www.nikon-asia.com/>

Visit these sites to keep up-to-date with the latest product information, tips, answers to frequently-asked questions (FAQs), and general advice on digital imaging and photography. Additional information may be available from the Nikon representative in your area. For contact information, visit <http://imaging.nikon.com/>

Wireless

This product, which contains encryption software developed in the United States, is controlled by the United States Export Administration Regulations and may not be exported or re-exported to any country to which the United States embargoes goods. The following countries are currently subject to embargo: Cuba, Iran, North Korea, Sudan, and Syria.

Notices for Customers in the U. S. A.

This device complies with Part 15 of the FCC Rules. Operation is subject to the following two conditions: (1) this device may not cause harmful interference, and (2) this device must accept any interference received, including interference that may cause undesired operation.

FCC WARNING

The FCC requires the user to be notified that any changes or modifications made to this device that are not expressly approved by Nikon Corporation may void the user's authority to operate the equipment.

FCC Radio Frequency Interference Statement

Note: This equipment has been tested and found to comply with the limits for a Class B digital device, pursuant to part 15 of the FCC Rules. These limits are designed to provide reasonable protection against harmful interference in a residential installation. This equipment generates, uses and can radiate radio frequency energy and, if not installed and used in accordance with the instructions, may cause harmful interference to radio communications. However, there is no guarantee that interference will not occur in a particular installation. If this equipment does cause harmful interference to radio or television reception, which can be determined by turning the equipment off and on, the user is encouraged to try to correct the interference by one or more of the following measures:

- Reorient or relocate the receiving antenna.
- Increase the separation between the equipment and receiver.
- Connect the equipment into an outlet on a circuit different from that to which the receiver is connected.
- Consult the dealer or an experienced radio/TV technician for help.

Co-location

This transmitter must not be co-located or operated in conjunction with any other antenna or transmitter.

Nikon Inc., 1300 Walt Whitman Road, Melville, New York 11747-3064, U.S.A.
Tel.: 631-547-4200

Notices for Customers in Canada

CAN ICES-3 B / NMB-3 B

This device complies with Industry Canada licence-exempt RSS standard(s). Operation is subject to the following two conditions: (1) this device may not cause interference, and (2) this device must accept any interference, including interference that may cause undesired operation of the device.

FCC/IC RF Exposure Statement

The available scientific evidence does not show that any health problems are associated with using low power wireless devices. There is no proof, however, that these low power wireless devices are absolutely safe. Low power Wireless devices emit low levels of radio frequency energy (RF) in the microwave range while being used. Whereas high levels of RF can produce health effects (by heating tissue), exposure of low-level RF that does not produce heating effects causes no known adverse health effects. Many studies of low-level RF exposures have not found any biological effects. Some studies have suggested that some biological effects might occur, but such findings have not been confirmed by additional research. The 1 V3, which is equipped with a LBWA1ZZYM6 (FCC ID:VPYLBYM / IC ID:772C-LBYM) wireless LAN module, has been tested and found to comply with FCC/IC radiation exposure limits set forth for an uncontrolled environment and meets the FCC radio frequency (RF) Exposure Guidelines in Supplement C to OET65 and RSS-102 of the IC radio frequency (RF) Exposure rules. Please refer to the SAR test report that was uploaded to FCC website.

Notices for Customers in Europe

Hereby, Nikon Corporation, declares that the 1 V3 is in compliance with the essential requirements and other relevant provisions of Directive 1999/5/EC. The declaration of conformity may be consulted at http://imaging.nikon.com/support/pdf/DoC_1V3.pdf



Notice for Customers in Singapore

Trade Name: Nikon Model: 1 V3

This device complies with radio-frequency regulations. The content of certification labels not affixed to the device is given below.

Complies with IDA Standards DA104328
--

Security

Although one of the benefits of this product is that it allows others to freely connect for the wireless exchange of data anywhere within its range, the following may occur if security is not enabled:

- Data theft: Malicious third-parties may intercept wireless transmissions to steal user IDs, passwords, and other personal information.
- Unauthorized access: Unauthorized users may gain access to the network and alter data or perform other malicious actions. Note that due the design of wireless networks, specialized attacks may allow unauthorized access even when security is enabled.

Introduction

Before You Begin

Before using your camera for the first time, confirm that the package contains the items listed in the *User's Manual*.



Parts of the Camera

Take a few moments to familiarize yourself with camera controls and displays. You may find it helpful to bookmark this section and refer to it as you read through the rest of the manual.

The Camera Body

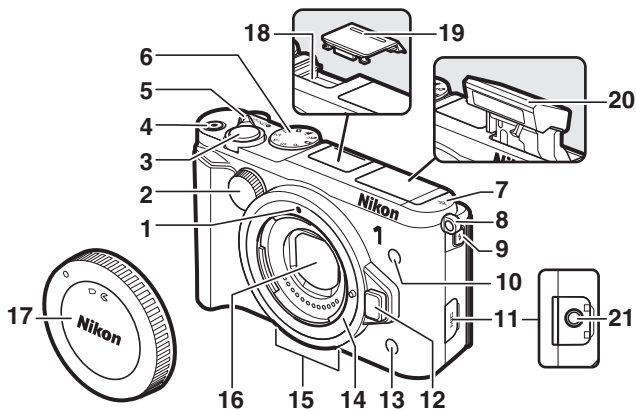

1 Mounting mark	27	11 External microphone connector cover	
2 Sub-command dial	72, 73	12 Lens release button	28
3 Shutter-release button	44, 64, 78, 81, 83, 88	13 Infrared receiver	96, 97, 241
4 Movie-record button	59, 60	14 Lens mount	27
5 Power switch	29	15 Microphone	193
6 Mode dial	8	16 Dust shield	227, 228
7 Focal plane mark (∞)	103	17 Body cap	223
8 Eyelet for camera strap	23	18 Multi accessory port	35, 109, 113
9 Flash pop-up button	105	19 Multi accessory port cover	34, 109, 113
10 AF-assist illuminator	186	20 Built-in flash	105
Self-timer lamp	95	21 Connector for external microphone	222
Red-eye reduction lamp	106		

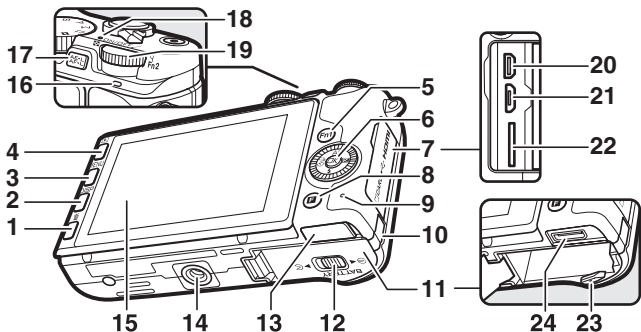

1 (delete) button.....	43, 136	11 Battery-chamber cover	24, 25, 225
2 DISP (display) button.....	6	12 Battery-chamber cover	
3 MENU (menu) button	10	latch.....	24, 25, 225
4 (playback) button	41, 85, 91	13 Grip connector cover	36
5 Fn1 button	14	14 Tripod socket *	
6 Multi selector.....	9	15 Vari-angle monitor	5, 15, 129, 211
(OK) button.....	9	16 Speaker	
AF (focus mode)	99	17 (AE/AF lock) button	214
(exposure compensation).....	104	18 Power lamp	29
(flash mode).....	105	19 Main command dial/ Fn2 button	14, 41, 71, 73, 102
(continuous shooting/ self-timer).....	92, 94, 96	20 HDMI connector.....	148
7 Memory card slot/connector cover	24, 26	21 USB connector.....	145, 150
8 (feature) button	12	22 Memory card slot.....	24
9 Memory card access lamp	26, 40	23 Battery latch.....	24, 25, 225
10 Power connector cover for optional power connector	225	24 Grip connector	36

* Camera does not support TA-N100 tripod mounting spacer.

Holding the Camera

When framing photographs, hold the camera as shown below.

*Hold the camera in your
right hand.*

*Keep your elbows propped
lightly against your torso.*



*Cradle the lens with
your left hand.*



The Monitor

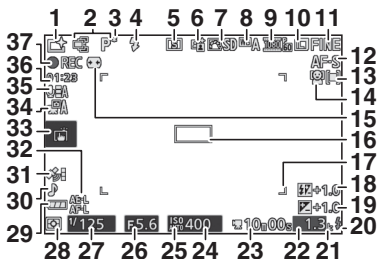

1 Shooting mode	8	20 Flash-ready indicator	107
2 Live image control	47	21 "k" (appears when memory remains for over 1000 exposures)	33
Creative mode	49	22 Number of exposures remaining	33
Best moment capture selection	76, 80, 82	Number of shots remaining before memory buffer fills	93
Advanced movie selection	59, 62	White balance recording indicator	199
Exposure mode	170	Card warning indicator	211, 244
3 Flexible program indicator	70	23 Time available	60
4 Flash mode	106	24 ISO sensitivity	201
5 Self-timer	94	25 ISO sensitivity indicator	201
Remote control mode	96	Auto ISO sensitivity indicator	201
Continuous mode *	92	26 Aperture	72, 73
6 Active D-Lighting *	179	27 Shutter speed	71, 73
7 Picture Control *	202	28 Metering	177
8 White balance *	196	29 Battery indicator *	33
9 Frame size/frame rate	192	30 Sound settings *	212
10 Image size *	172	31 Satellite signal indicator *	115
11 Image quality *	171	32 Autoexposure (AE)/autofocus (AF) lock indicator	214
12 Focus mode *	99	33 Tap shooting options	116
13 AF-area mode *	185	34 Auto image capture	194
14 Face-priority *	45, 169	35 Microphone sensitivity *	193
15 Auto distortion control indicator	178	36 Time elapsed	60
16 Focus area	39, 185	37 Recording indicator	60
17 AF-area brackets *	99		
18 Flash compensation	188		
19 Exposure compensation	104		

* Available only in detailed display (□ 6).

Note: Display shown with all indicators lit for illustrative purposes.

The DISP (Display) Button

Press DISP to cycle through shooting (5) and playback (129) indicators as shown below.

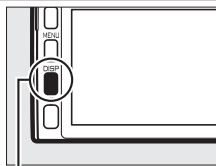

DISP button



Shooting

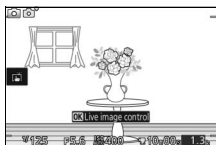

Simplified display

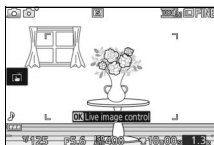

Detailed display

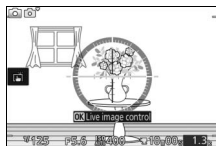

*Virtual horizon**

* Displayed only in modes other than **Creative Palette**.

Recording Area

The area recorded during movie recording is shown by guides in the display; the appearance of the guides depends on the option selected for **Electronic VR** (184) in movie menu.

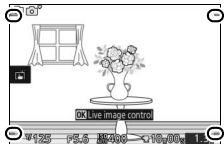

Electronic vibration reduction off

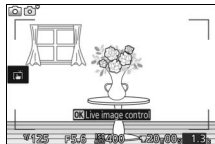

Electronic vibration reduction on

Playback

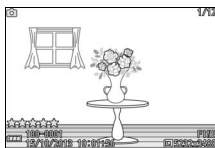

Simple photo info

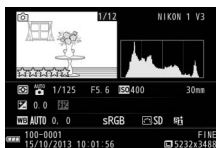

Detailed photo info

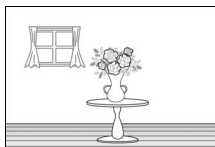
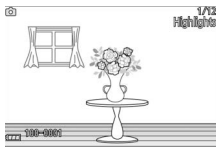

Image only



Highlights*

*Displayed only when **On** is selected for the **Display > Playback highlight display** option in the setup menu (p. 212).

Virtual Horizon

Display roll and pitch information based on information from the camera tilt sensor. If the camera is tilted neither left nor right, the roll reference line will turn green, while if the camera is tilted neither forward nor back, the dot in the center of the display will turn green. Each division on the rolling display is equivalent to 5°, while each division on the pitch display is equivalent to 10°.



Camera level



Camera tilted left or right



Camera tilted forward or back

Tilting the Camera

The virtual horizon display is not accurate when the camera is tilted at a sharp angle forward or back. If the camera is unable to measure tilt, the amount of tilt will not be displayed.



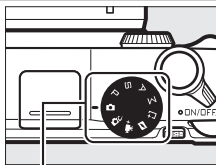

The Mode Dial

The camera offers a choice of the following shooting modes:





Mode dial

 **Auto mode** (□ 38): Let the camera pick the settings for photographs and movies.

 **Creative mode** (□ 49): For photographs in which you want to use special effects or match settings to the scene.

 **Advanced movie mode** (□ 59): Choose an exposure mode and adjust shutter-speed or aperture or record movies in slow or fast motion or with other special effects.

 **Motion Snapshot mode** (□ 87): Each time the shutter is released, the camera records a still image and about 1.6 s of movie footage.

 **Best moment capture mode** (□ 76): Choose **Active Selection** to select the best picture from 40 shots in temporary storage, **Slow view** to choose the best timing for the shot while the scene plays back in slow motion, or **Smart Photo Selector** to let the camera pick the best shot based on composition and movement.

P, S, A, and M modes (□ 69): Control shutter speed and aperture for advanced photographic effects.

- **P**: Programmed auto (□ 70)
- **A**: Aperture-priority auto (□ 72)
- **S**: Shutter-priority auto (□ 71)
- **M**: Manual (□ 73)

The Multi Selector

The multi selector and  button are used to adjust settings and navigate the camera menus.

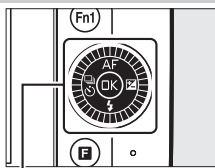

Multi selector



Settings: AF

View focus mode menu ( 99).

Menu navigation: ▲

Move cursor up.

Settings:

View continuous shooting/self-timer/remote control menu ( 92, 94, 96).

Menu navigation: ◀

Return to previous menu.



Select highlighted item.

Settings:

View exposure compensation menu ( 104).

Menu navigation: ▶

Select highlighted item or display sub-menu.

Settings:

View flash mode menu ( 105).

Menu navigation: ▼

Move cursor down.

The Multi Selector

Items can be highlighted by rotating the multi selector as shown at right.



The MENU Button



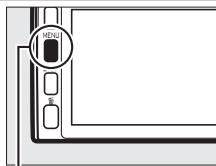





Most shooting, playback, and setup options can be accessed from the camera menus. To view the menus, press the MENU button.



MENU button

Tabs

Choose from the following menus:

-  Playback menu (📖 156)
-   P S A M   Shooting menu (📖 167)
-  Movie menu (📖 189)
-  Image processing menu (📖 195)
-  Setup menu (📖 209)
-  Wi-Fi menu (📖 119)

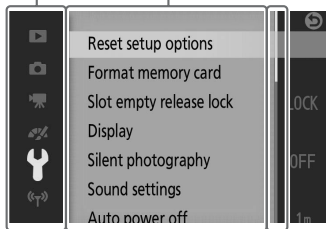

Menu options
Options in current menu.

Slider shows position in current menu.

■ Using the Menus

Use the multi selector (📖 9) to navigate the playback, shooting, movie, image processing, setup, and Wi-Fi menus.

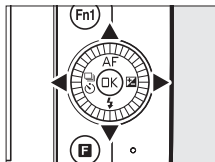

Multi selector

1 Select a menu.

Press ▲ or ▼ to highlight tabs and press ► to position the cursor in the highlighted menu.

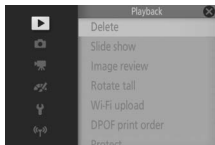

2 Select an item.

Press ▲ or ▼ to highlight menu items and press ► to view options for the highlighted item.

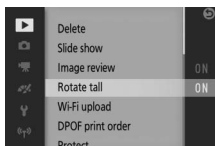

3 Select an option.

Press ▲ or ▼ to highlight the desired option and press **OK** to select.

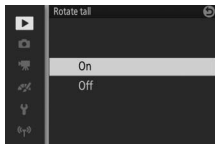

🔍 Using the Menus

The items listed may vary with camera settings. Items displayed in gray are not currently available (📖 232). To exit the menus and return to shooting mode, press the shutter-release button halfway (📖 44).



The **F** (Feature) Button

To display the feature menu and adjust camera settings or access playback options, press the **F** button.

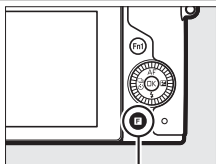

F button

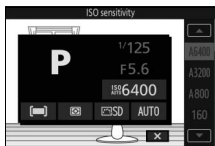

F menu (shooting mode)

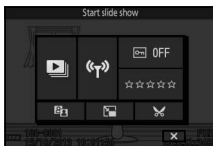

F menu (playback)

1 Select an item.

Use the multi selector to highlight an item and press **OK** to display options (to exit the **F** menu, press the shutter-release button halfway as described on page 44 or highlight **X** and press **OK**).

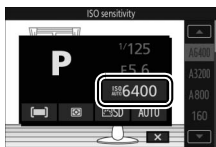

2 Select an option.

Highlight the desired option or value and press **OK** to select.

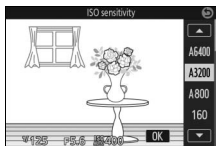

The **F** Menu

The **F** menu is context-sensitive: its contents vary with camera settings or the type of image displayed; options that are currently unavailable are shown in gray. The **F** menu is not available in auto mode.



The Function Buttons (Fn1 and Fn2)

The **Fn1** and **Fn2** buttons can be used for quick recall of frequently-used settings during shooting. To choose the roles these buttons play, go to **Assign Fn button** in the setup menu (☞ 209), highlight the desired button, press **▶**, and choose from the following options:



Fn2 button

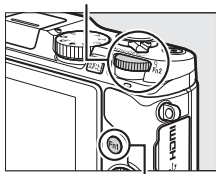

Fn1 button

- Exposure compensation (☞ 104)
- Metering (☞ 177)
- White balance (☞ 196)
- ISO sensitivity (☞ 201)
- Picture Control (☞ 202)
- AF-area mode (☞ 185)
- Movie-record button

If **Movie-record button** is selected, the chosen button can be used to start and end movie recording (☞ 60).

Users of the optional grip (☞ 36) can also choose the role played by the **Fn3** button.

Fn3 button

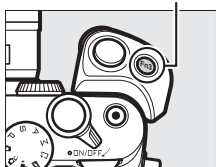

Default Settings

At default settings, the **Fn1**, **Fn2**, and **Fn3** buttons are respectively assigned white balance, ISO sensitivity, and movie recording functions.

The Fn2 Button

The main command dial doubles as the **Fn2** button. To access the function assigned to the **Fn2** button, press the command dial.

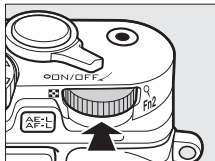

Fn2 button

Using the Vari-Angle Monitor

The monitor can be angled and rotated as shown below.

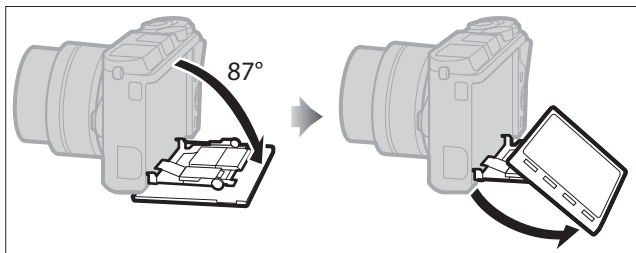

Normal use: The monitor is normally used in storage position.

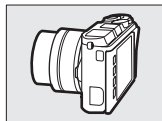

Low-angle shots: Frame shots with the camera close to the ground. Once in the low-angle position, the monitor can be further lowered.

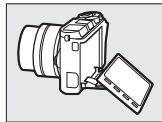
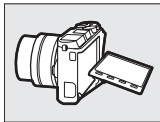
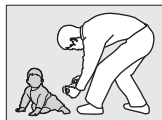
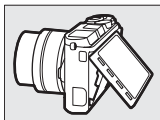

High-angle shots: Frame shots while holding the camera over your head.

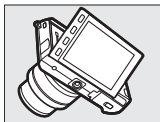

✔ Using the Monitor

Rotate the monitor gently within the limits shown on page 15. *Do not use force.* Failure to observe these precautions could damage the camera or monitor. If the camera is mounted on a tripod, care should be taken to ensure that the monitor does not contact the tripod.

Do not touch the area to the rear of the monitor. Failure to observe this precaution could cause product malfunction.

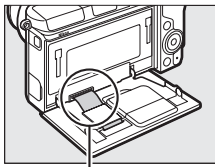

Be particularly careful not to touch this area.

Using the Touch Screen

The touch-sensitive monitor supports the following operations:

Tap

Tap the monitor.



Flick

Flick a finger a short distance across the monitor.

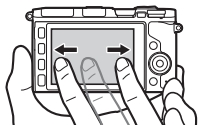

Slide

Slide a finger over the monitor.

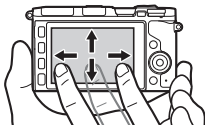

Stretch/Pinch

Place two fingers on the monitor and move them apart or pinch them together.

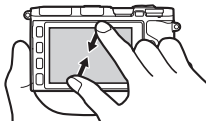

 **The Touch Screen**

The touch screen responds to static electricity and may not respond when covered with third-party protective films or when touched with fingernails or gloved hands. Do not use excessive force or touch the screen with sharp objects.

 **Using the Touch Screen**

The camera may not recognize a tap if you leave your finger on the screen too long. It may not recognize other gestures if your touch is too soft, your fingers are moved too quickly or too short a distance or do not remain in contact with the screen, or if the movement of the two fingers in a pinch or stretch is not correctly coordinated.



■ Taking Pictures

The touch screen can be used for the following shooting operations.

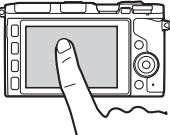
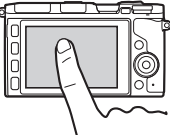
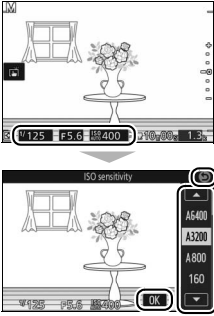
Take a picture (tap shooting)		In auto, creative, P, S, A, and M modes, you can focus and take a picture by tapping your subject in the display.
Focus (tap shooting)		In advanced movie mode, you can focus by tapping your subject in the display.
Adjust settings		Tap highlighted icons to view settings and tap icons or sliders to change (the items available vary with camera settings). Tap OK to save changes and exit, or tap ⏪ to return to the previous display.





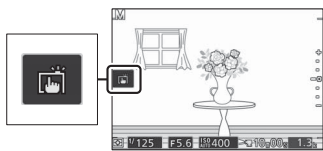

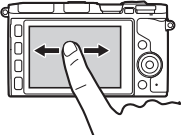

🔍 Tap Shooting Options

Tap shooting options can be adjusted by tapping the icon shown at right (📖 116).

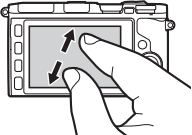

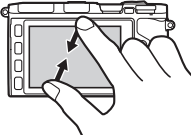
■ Viewing Pictures

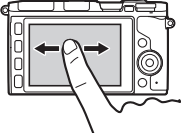
The touch screen can be used for the following playback operations.

 View other images		Flick left or right to view other images.
View movies or panoramas	 <i>Guide</i>	Tap the on-screen guide to start movie or panorama playback (movies are indicated by a  icon). Tap the display to pause or resume.
Zoom in		Use stretch and pinch gestures to zoom in and out and slide to scroll. You can also double-tap a picture in full-frame playback to zoom in and double-tap again to exit zoom ( 135).
View thumbnails		To “zoom out” to a thumbnail view ( 133), use a pinch gesture in full-frame playback. Use pinch and stretch to choose the number of images displayed from 4, 9, or 16 frames.
View other months		Flick left or right to view other months in the calendar display ( 134).

Use on-screen guides



Various operations can be performed by tapping on-screen guides.

■ Using the Menus

The touch screen can be used for the following menu operations.



Scroll

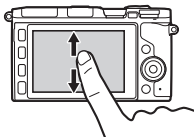

Slide up or down to scroll.

Choose a menu

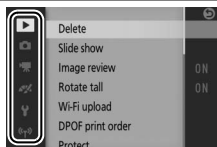

Tap a menu icon to choose a menu.

Adjust settings





Tap menu items to display options and tap icons or sliders to change. Tap  to return to the previous display.

■ The **F** Menu

The touch screen can be used to adjust settings in the **F** menu.

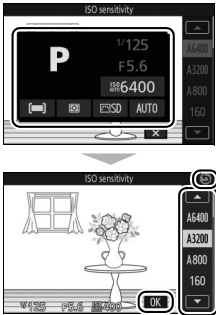
Adjust settings



Tap menu items to display options and tap icons or sliders to change. Tap **OK** to save changes and exit, or tap  to return to the previous display.

First Steps

1 Attach the camera strap.

Attach the strap securely to the two camera eyelets.

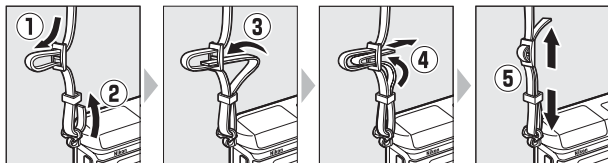

2 Charge the battery.

Insert the battery into the charger ① and plug the charger in ②. An exhausted battery fully charges in about 3 hours. Unplug the charger and remove the battery when charging is complete.

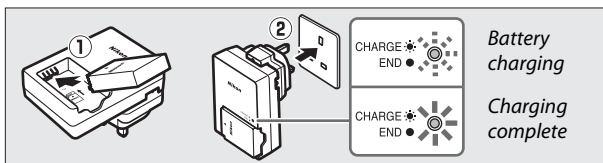

The Plug Adapter

Depending on the country or region of purchase, a plug adapter may be supplied with the charger. The shape of the adapter varies with the country or region of purchase. If a plug adapter is supplied, raise the wall plug and connect the plug adapter as shown at right, making sure the plug is fully inserted. Attempting to forcibly remove the plug adapter could damage the product.

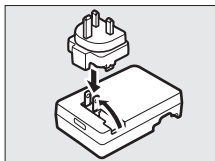

3 Insert the battery.

Insert the battery in the orientation shown, using the battery to keep the orange battery latch pressed to one side. The latch locks the battery in place when the battery is fully inserted.

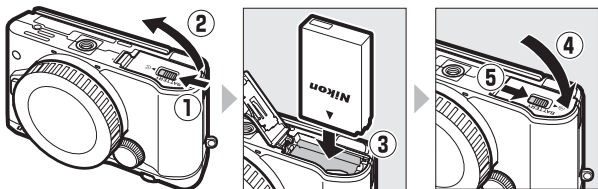

4 Insert a memory card.

The camera stores pictures on microSD, microSDHC, and microSDXC memory cards (available separately; [book 224](#)). Check to be sure the card is in the correct orientation and then slide the card until it clicks into place. Do not attempt to insert the card at an angle; failure to observe this precaution could damage the product.

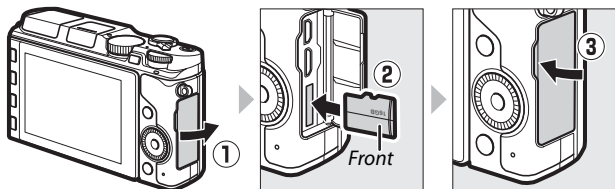

✓ Inserting and Removing Batteries and Memory Cards

Always turn the camera off before inserting or removing batteries or memory cards. Note that the battery and memory cards may be hot after use; observe due caution when removing the battery and memory cards.

✎ Removing the Battery

To remove the battery, turn the camera off and open the battery-chamber cover. Press the battery latch in the direction shown by the arrow to release the battery and then remove the battery by hand.

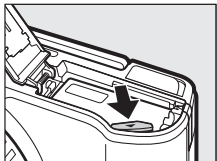

✓ The Battery and Charger

Read and follow the warnings and cautions on pages xi–xiii and 228–231 of this manual. Do not use the battery at ambient temperatures below 0°C (32°F) or above 40°C (104°F); failure to observe this precaution could damage the battery or impair its performance. Capacity may be reduced and charging times may increase at battery temperatures from 0°C (32°F) to 10°C (50°F) and from 45°C (113°F) to 60°C (140°F); the battery will not charge if its temperature is below 0°C (32°F) or above 60°C (140°F).

Charge the battery at ambient temperatures between 5°C (41°F) and 35°C (95°F). If the **CHARGE** lamp flashes quickly during charging, cease use immediately and take battery and charger to your retailer or a Nikon-authorized service representative.

Do not move the charger or touch the battery during charging. Failure to observe this precaution could in very rare instances result in the charger showing that charging is complete when the battery is only partially charged. Remove and reinsert the battery to begin charging again.

Use the charger with compatible batteries only. Unplug when not in use.



Formatting Memory Cards

If this is the first time the memory card will be used in the camera or if the card has been formatted in another device, select **Format memory card** in the setup menu and follow the on-screen instructions to format the card (☐ 211). *Note that this permanently deletes any data the card may contain.* Be sure to copy any photographs and other data you wish to keep to a computer before proceeding.

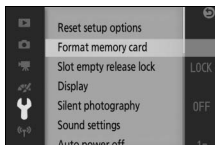

Removing Memory Cards

Turn the camera off and confirm that the memory card access lamp is off, then open the memory card slot/connector cover and press the card in to eject it (①). The card can then be removed by hand (②). Care should be taken to prevent the card popping from the camera when ejected.

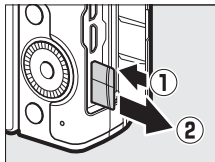

Memory Cards

- Do not remove memory cards from the camera, turn the camera off, or remove or disconnect the power source during formatting or while data are being recorded, deleted, or copied to a computer. Failure to observe these precautions could result in loss of data or in damage to the camera or card.
- Do not touch the card terminals with your fingers or metal objects.
- Do not bend, drop, or subject to strong physical shocks.
- Do not apply force to the card casing. Failure to observe this precaution could damage the card.
- Do not expose to water, heat, high levels of humidity, or direct sunlight.
- Do not format memory cards in a computer.

5 Attach a lens.

Be careful to prevent dust from entering the camera when the lens or body cap is removed. The lens generally used in this manual for illustrative purposes is a 1 NIKKOR VR 10–30mm f/3.5–5.6 PD-ZOOM. When using the 1 NIKKOR VR 10–30mm f/3.5–5.6 PD-ZOOM, be sure not to touch the lens cover (☞ 256); failure to observe this precaution could result in product malfunction.

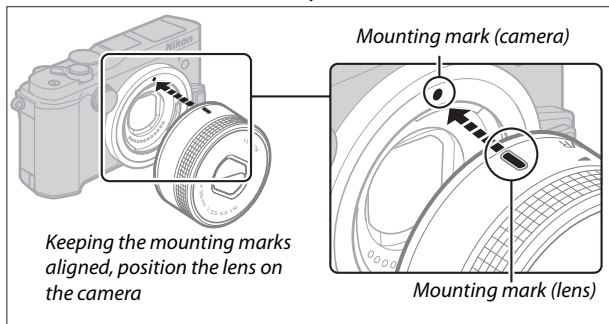
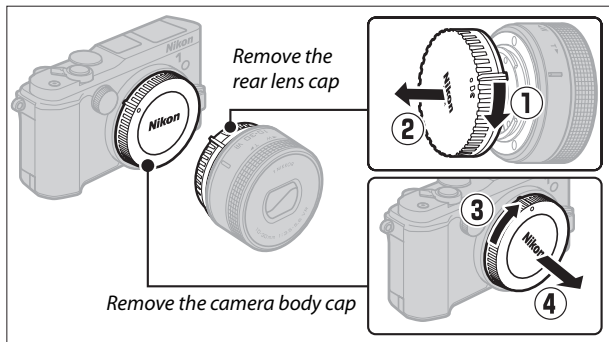

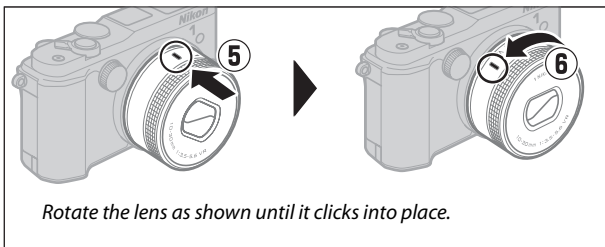

If the lens supports vibration reduction (VR), vibration reduction can be controlled from the camera (📖 183).

🔍 Detaching the Lens

Be sure the lens is retracted before removal. To remove the lens, turn the camera off, then press and hold the lens release button (1) while turning the lens clockwise (2). After removing the lens, replace the camera body cap, the rear lens cap, and, if applicable, the front lens cap.

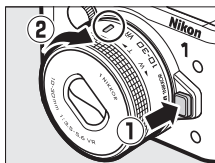

🔍 Lenses with Retractable Lens Barrel Buttons

Lenses with retractable lens barrel buttons can not be used when retracted. To unlock and extend the lens, readying the camera for use, keep the retractable lens barrel button pressed (1) while rotating the zoom ring as shown (2). The lens can be retracted and the zoom ring locked by pressing the button and rotating the ring in the opposite direction. Be careful not to press the retractable lens barrel button while attaching or removing the lens.

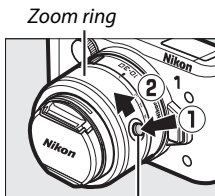

Retractable lens barrel button

6 Turn the camera on.

Rotate the power switch to turn the camera on. The power lamp will briefly light green and the monitor will turn on. If the lens is equipped with a front lens cap, remove the cap before shooting. If a 1 NIKKOR VR 10–30mm f/3.5–5.6 PD-ZOOM lens is attached, the lens will automatically extend when the camera is turned on and retract when the camera is turned off.

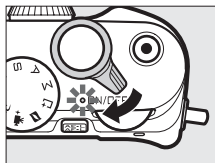

Turning the Camera Off

To turn the camera off, rotate the power switch again. The monitor will turn off.

Auto Power Off

If no operations are performed for about a minute, the displays will turn off and the power lamp start to flash (if desired, the delay before the displays turn off automatically can be changed using the **Auto power off** option in the setup menu; □ 213). The camera can be reactivated by operating the shutter-release button. If no operations are performed for about three minutes after the displays have turned off, the camera will turn off automatically.



Attaching and Removing Lenses

Turn the camera off before attaching or removing lenses. Note that when the camera is turned off, the sensor protection barrier in the lens will close, protecting the camera image sensor.

Lenses with Retractable Lens Barrel Buttons

The camera will turn on automatically when the retractable lens barrel lock is released; in addition, if the view through the lens is displayed or the monitor is off, the camera will turn off when the lens barrel is locked (in the case of 1 NIKKOR VR 10–30mm f/3.5–5.6 and 1 NIKKOR VR 30–110mm f/3.8–5.6 lenses, firmware version 1.10 or later is required if locking the lens barrel is to turn the camera off when the monitor is off; for information on updating lens firmware, visit the Nikon website for your area).

7 Choose a language.

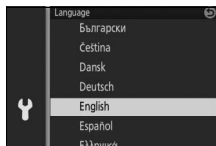

A language-selection dialog will be displayed the first time the camera is turned on. Use the multi selector and  button ( 9) to choose a language.





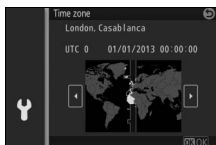
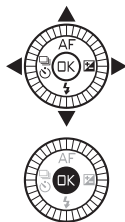

8 Set the clock.

Use the multi selector and  button (📖 9) to set the time and date. *Note that the camera uses a 24-hour clock.*

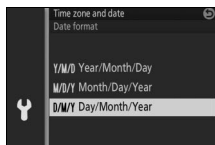



Press  or  to highlight time zone and press .



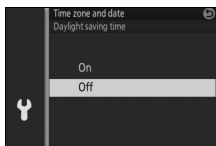



Press  or  to highlight date format and press .

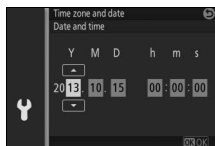

Press  or  to highlight daylight saving time option and press .



Press  or  to highlight items and press  or  to change. Press  to exit to shooting display when setup is complete.

Note: Language and clock can be changed at any time using **Language** (📖 210) and **Time zone and date** (📖 218) options in setup menu.



 **The Camera Clock**

The camera clock is less accurate than most watches and household clocks. Check the clock regularly against more accurate time pieces and reset as necessary.

The camera clock is powered by an independent, rechargeable power source, which is charged as necessary when the main battery is installed or the camera is powered by an optional power connector and AC adapter (☐ 222). Three days of charging will power the clock for about a month. If a message warning that the clock is not set is displayed when the camera is turned on, the clock battery is exhausted and the clock has been reset. Set the clock to the correct time and date.



9 Check the battery level and memory card capacity.



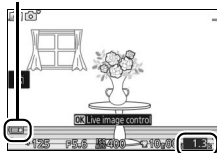

Check the battery level and number of exposures remaining in the monitor.

Battery level





Exposures remaining

■ ■ Battery Level

Display	Description
NO ICON	Battery fully charged or partially discharged; level shown by  or  icon in detailed display ( 6).
	Low battery. Ready fully-charged battery or prepare to charge battery.
Cannot take pictures. Insert fully-charged battery.	Battery exhausted; shutter-release disabled. Insert charged battery.

■ ■ Number of Exposures Remaining

The monitor shows the number of pictures that can be stored on the memory card at current settings (values over 1000 are rounded down to the nearest hundred; e.g., values between 1200 and 1299 are shown as 1.2 k). If a warning is displayed stating that there is not enough memory for additional images, insert another memory card ( 24) or delete some photos ( 136).



Attaching a Grip and Electronic Viewfinder

If desired, the camera can be used with an optional grip and electronic viewfinder (☐ 221). Manuals are not provided; users of these accessories will need to read following instructions in their entirety before proceeding.

Attaching an Electronic Viewfinder

Viewfinder eyepiece

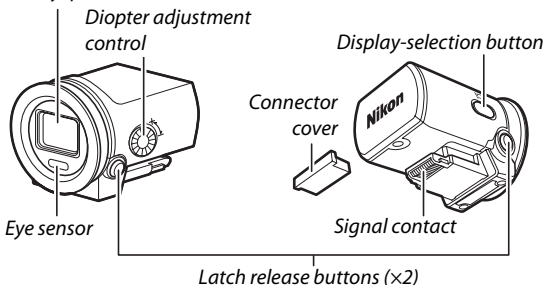

Follow the steps below to attach the viewfinder.

1 Remove the multi-accessory port cover.

Remove the cover from the camera as shown. Be sure to replace the cover when the port is not in use.

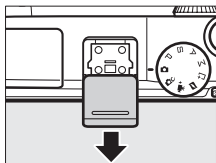

2 Remove the connector cover.

Remove the connector cover from the electronic viewfinder. Be sure to replace the cover when the viewfinder is not in use.

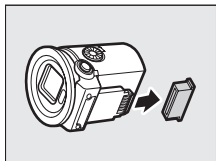

3 Attach the viewfinder.

After confirming that the camera is off, slide the signal contact into the multi-accessory port until it latches.

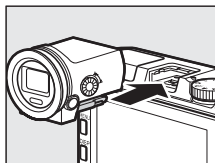

Handling the Viewfinder

Remove the viewfinder when it is not in use. If the viewfinder is attached, the shocks and vibration to which the camera may be exposed during transport or when placed in a bag could damage the camera or viewfinder. To remove the viewfinder, confirm that the camera is off and then press and hold the latch release buttons while detaching the viewfinder from the multi accessory port.

Do not touch the viewfinder signal contact. Failure to observe this precaution could cause product malfunction.

Using the Viewfinder

Use the viewfinder when bright ambient lighting conditions make it difficult to see the display in the monitor. When you put your eye to the viewfinder, the eye sensor will turn the viewfinder on and the monitor off (note that the sensor responds to more than just your eyes; when using the monitor, keep your fingers and other objects from the sensor). You can also use the display-selection button to cycle through display settings as follows: automatic display selection (**Eye sensor on**); viewfinder on, monitor off (**Eye sensor off**); and monitor on, viewfinder off. The eye sensor is re-enabled automatically each time the camera is turned on. While the viewfinder is on, you can use the DISP button to view or hide indicators (6).

Viewfinder Focus

If you find that the icons and other indicators displayed in the viewfinder seem blurry, rotate the diopter adjustment control until the display is in sharp focus. When operating the control with your eye to the viewfinder, be careful not to put your fingers or fingernails in your eyes.

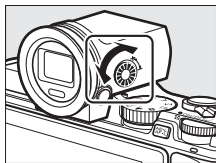

Attaching a Grip

Fn3 button (☞ 14)

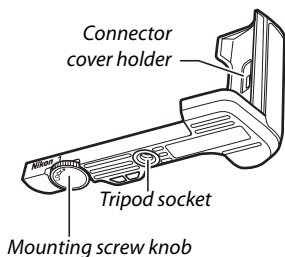
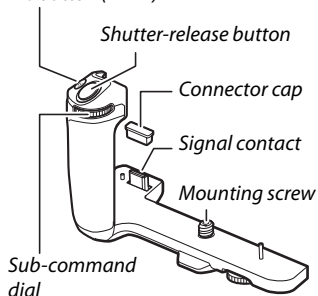

Follow the steps below to attach the grip.

1 Remove the grip connector cover.

Remove the grip connector cover from the bottom of the camera and place it in the holder. Be sure to replace the cover when the grip is not in use.

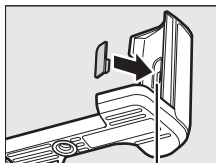
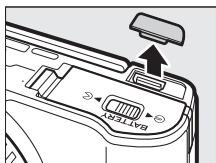

Connector cover holder

2 Remove the connector cap.

Remove the grip connector cap. Be sure to replace the cap when the grip is not in use.

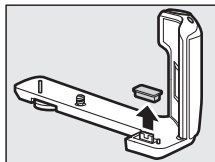

3 Attach the grip.

After confirming that the camera is off, align the camera and grip as shown and tighten the knob by rotating it in the **LOCK** direction, keeping the grip held in place so that the grip signal contact slides straight into the camera grip connector.

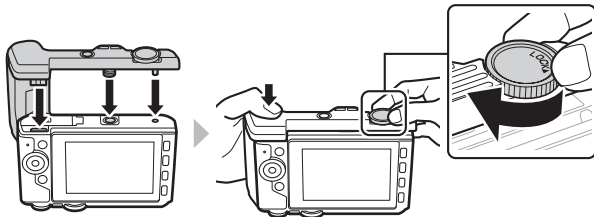

Removing the Grip

To remove the grip, confirm that the camera is off and then loosen the mounting screw by rotating the knob in the direction opposite to that shown by the **LOCK** indicator.

Handling the Grip

Do not touch the signal contacts. Failure to observe this precaution could cause product malfunction.

Taking and Viewing Photographs

This chapter describes how to take, view, and delete photographs in auto and creative mode.

Point-and-Shoot Photography (Auto Mode)

Follow the steps below to take photographs in auto mode, a “point-and-shoot” mode in which the camera automatically detects the subject type and adjusts settings according to the subject and situation.

1 Turn the camera on.

Rotate the power switch to turn the camera on.

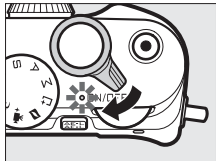

2 Select mode.

Rotate the mode dial to  (auto).

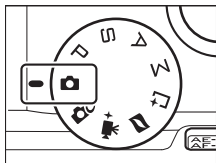

3 Ready the camera.

Hold the camera securely with both hands, being careful not to obstruct the lens, AF-assist illuminator, or microphone. Rotate the camera as shown at lower right when taking pictures in “tall” (portrait) orientation.

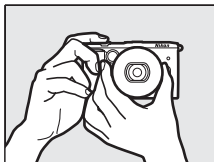

Shutter speeds slow when lighting is poor; use of the built-in flash (📖 105) or a tripod is recommended.

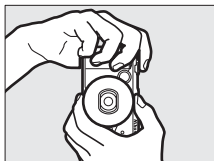

4 Frame the photograph.

Position your subject in the center of the frame.

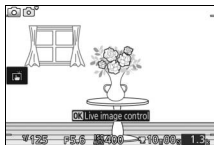

5 Focus.

Press the shutter-release button halfway to focus. If the subject is poorly lit, the AF-assist illuminator (📖 186) may light to assist the focus operation.

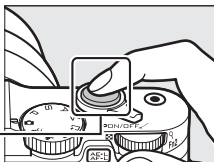

If the camera is able to focus, the selected focus area will be highlighted in green and a beep will sound (a beep may not sound if the subject is moving).

Focus area

If the camera is unable to focus, the focus area will be displayed in red.

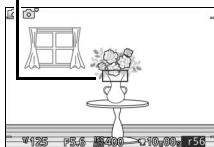

6 Shoot.

Smoothly press the shutter-release button the rest of the way down to release the shutter and record the photograph. The memory card access lamp will light and the photograph will be displayed in the monitor for a few seconds (the photo will automatically clear from the display when the shutter-release button is pressed halfway). *Do not eject the memory card or remove the battery until the lamp has gone out and recording is complete.*

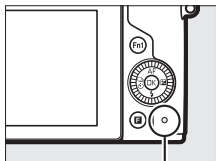
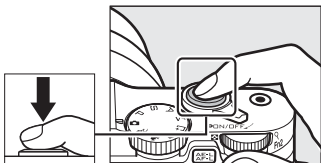

Memory card access lamp

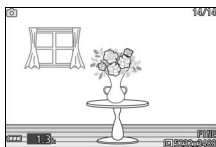

The Framing Grid

A framing grid can be displayed by selecting **On** for **Display > Grid display** in the setup menu (212).

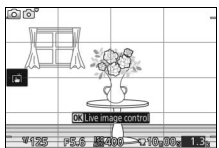

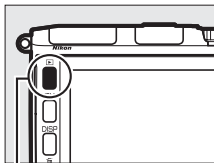

Viewing Photographs

Press  to display your most recent photograph full frame in the monitor (full-frame playback).



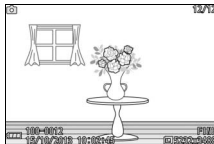

 button



Press  or  or rotate the multi selector to view additional pictures.



To zoom in on the center of the current image, rotate the main command dial to the right ( 135). Rotate left to zoom out. To view multiple images, rotate the dial left when the picture is displayed full frame ( 133).

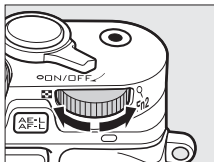

Main command dial

To end playback and return to shooting mode, press the shutter-release button halfway.

The **F** (Feature) Menu (🗨️ 12)

The following options can be accessed by pressing **F** when a photo is displayed:

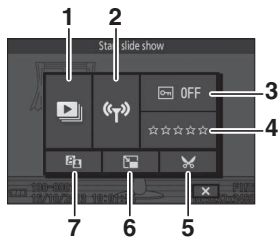

1	Start slide show	138
2	Wi-Fi upload	125
3	Protect	159
4	Rating	160
5	Crop	162
6	Resize	161
7	D-Lighting.....	160

Deleting Pictures

To delete the current picture, press . *Note that once deleted, pictures can not be recovered.*

1 Display the photograph.

Display the photograph you wish to delete as described on the preceding page.

2 Press .

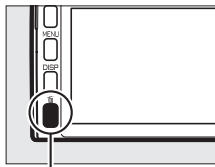

A confirmation dialog will be displayed.

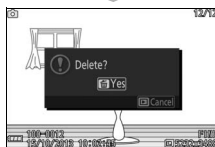

 button



3 Delete the photograph.

Press  again to delete the picture and return to playback, or press  to exit without deleting the picture.

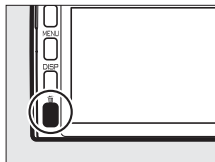

The Shutter-Release Button

The camera has a two-stage shutter-release button. The camera focuses when the shutter-release button is pressed halfway. To take the photograph, press the shutter-release button the rest of the way down.



Focus: Press halfway



Shoot: Press the rest of the way down

Taking Several Photographs in Succession

If **Off** is selected for **Image review** in the playback menu (📖 159), you can take additional photographs without refocusing by keeping the shutter-release button pressed halfway between shots.

Automatic Scene Selection

In auto mode, the camera automatically analyzes the subject and selects the appropriate scene. The selected scene is shown in the monitor.

Scene icon

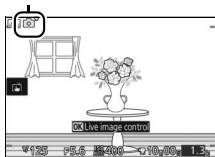

 **Portrait:** Human portrait subjects.

 **Landscape:** Landscapes and cityscapes.

 **Night portrait:** Portrait subjects framed against dark backgrounds.

 **Close up:** Subjects close to the camera.

 **Night landscape:** Poorly-lit landscapes and cityscapes.

 **Auto:** Subjects that do not fall into the categories listed above.

Using a Zoom Lens

Use the zoom ring to zoom in on the subject so that it fills a larger area of the frame, or zoom out to increase the area visible in the final photograph. During movie recording with the 1 NIKKOR VR 10–30mm f/3.5–5.6 PD-ZOOM, the zoom rate is unaffected by the speed with which the ring is rotated.

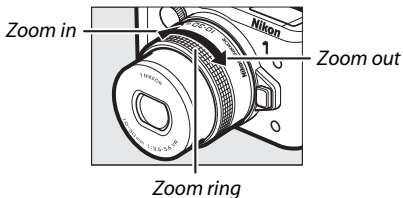

If you are using a 1 NIKKOR VR 10–100mm f/4.5–5.6 PD-ZOOM lens (available separately), slide the power drive zoom switch to **T** to zoom in and to **W** to zoom out. The speed with which the camera zooms in and out varies with how far you slide the switch. The zoom position is shown by the zoom guide in the display.

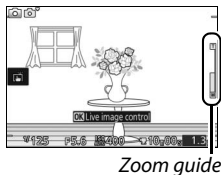

Face Priority

The camera detects and focuses on portrait subjects (face priority). A double yellow border will be displayed if a portrait subject is detected facing the camera (if multiple faces, up to a maximum of five, are detected, the camera will select the closest subject). Press the shutter-release button halfway to focus on the subject in the double yellow border. The border will clear from the display if the camera can no longer detect the subject (because, for example, the subject has looked away).



Available Settings

For information on the options available in auto mode, see page 232.



Deleting Multiple Pictures

The **Delete** option in the playback menu (☐ 136) can be used to delete selected pictures, all pictures, or pictures taken on selected dates.

See Also

See page 212 for information on silencing the beep that sounds when the camera focuses or the shutter is released. For information on toggling photo info on or off, see page 7. See page 138 for information on slide shows.



Live Image Control

Live image controls let you preview how changes to each control will affect the final photograph. To choose a live image control for auto mode, press **OK** to display the live image control menu, then use the multi selector to highlight a control and press **OK** to view the effect. Rotate the multi selector to choose a setting and press **OK** to select.



Active D-Lighting: Preserve details in highlights and shadows for natural contrast.



Active D-Lighting: High *Active D-Lighting: Low*

Background softening: Soften background details to make your subject stand out, or bring both background and foreground into focus.



Background sharp

Background softened

Increase effect



Reduce effect

Sharpen background

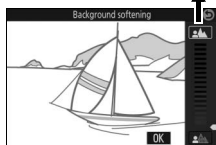

Soften background

Motion control: Suggest motion by blurring moving objects, or “freeze” motion to capture moving objects clearly.



Freeze motion

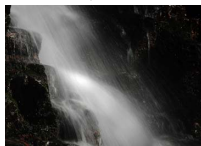

Blur motion

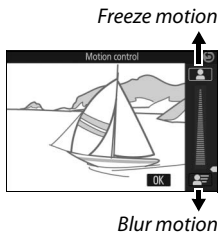

Brightness control: Make pictures brighter or darker.



Brighter



Darker

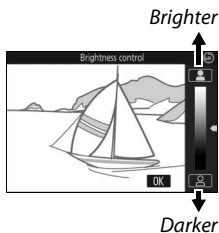

Live Image Control

Continuous shooting is not available (92) and the built-in flash and optional flash units can not be used when live image control is in effect. Pressing the movie-record button cancels live image control.

Choosing a Creative Mode

Choose creative mode to match settings to the subject or situation or take photos using special effects.

1 Select **CC** mode.

Rotate the mode dial to **CC** (creative).

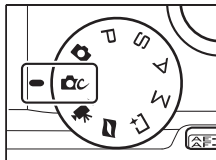

2 Choose an option.

Press **F** (feature) to display the **F** menu, then highlight **Creative** and press **OK**. Highlight an option suited to your subject and creative intent (see page 50) and press **OK**.

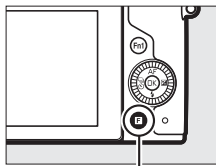

F button

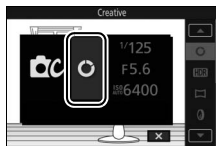

Choosing a Mode That Matches the Subject or Situation

Choose a creative mode according to the subject or situation:

Option	Description
Creative Palette (C)	Rotate the palette to choose creative effects while previewing them in the display (□ 52).
HDR (HDR)	Photograph high-contrast scenes (□ 53).
Easy panorama (P)	Shoot panoramas for later viewing on the camera (□ 54).
Soft (S)	Shoot photographs with a soft filter effect. Use the F (Feature) menu (□ 51) to select the amount of softening and to choose how softening applies to portraits (□ 176).
Miniature effect (M)	The top and bottom of each photo is blurred so that the subject appears to have been a diorama photographed at short range. Works best when shooting from a high vantage point.
Selective color (S)	Take photos in which only a selected hue appears in color (□ 57).
Cross process (X)	Choose a base color to create photographs with different hues (□ 58).
Toy camera effect (T)	Alter color saturation and reduce peripheral illumination for a toy camera effect (□ 177). The effect can be adjusted using the F menu (□ 51).



The **F** (Feature) Menu (📖 12)

Pressing **F** in creative mode displays the items listed below. The items available vary with the option selected for creative mode (📖 50).

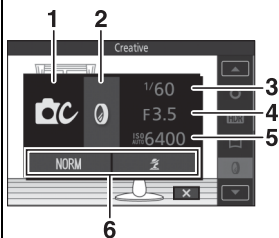

1	Shooting mode.....	8
2	Creative.....	49
3	Shutter speed.....	71, 73
4	Aperture.....	72, 73
5	ISO sensitivity.....	201
6	Image size.....	172
	Filter strength.....	176
	Portrait.....	176
	Select color.....	57
	Hue.....	58
	Saturation.....	177
	Vignetting.....	177

Available Settings

For information on the options available in creative mode, see page 234.



The Creative Palette

To choose a creative effect, rotate the multi selector or use a finger to rotate the creative palette in the monitor. The selected effect is visible in the monitor and changes gradually as the palette is rotated.

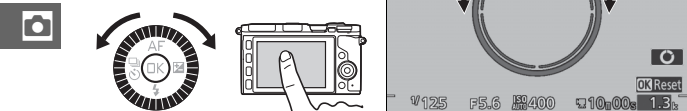

Press the shutter-release button all the way down to take a picture with the selected effect (tap shooting options are not available when the creative palette is displayed; to view or hide the creative palette, tap **OK**). The built-in flash and optional flash units can not be used.

Scene Detection

The camera automatically adjusts settings to suit the subject and situation. The effects available vary with the type of subject detected. To reset the palette, press **OK** or tap **Reset** while the creative palette is displayed.

HDR

Details in highlights and shadows are preserved using HDR (high dynamic range). Each time the shutter-release button is fully pressed, the camera takes two shots in quick succession and combines them to preserve details in highlights and shadows in high-contrast scenes; the built-in flash and optional flash units do not fire. Some time may be required to process the pictures; the final photograph will be displayed when processing is complete.



Framing HDR Photographs

The edges of the image will be cropped out. The desired results may not be achieved if the camera or subject moves during shooting. Depending on the scene, shading may be uneven and shadows may appear around bright objects or halos around dark objects.



Easy Panorama

Follow the steps below to shoot panoramas. During shooting, the camera focuses using auto-area AF (📖 185); face detection (📖 45) is not available. Exposure compensation (📖 104) can be used, but the built-in flash and optional flash units will not fire.

1 Set focus and exposure.

Frame the start of the panorama and press the shutter-release button halfway. Guides will appear in the display.

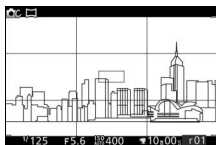

2 Start shooting.

Press the shutter-release button the rest of the way down and then lift your finger from the button. ▲, ▼, ◀, and ▶ icons will appear in the display to indicate the possible pan directions.

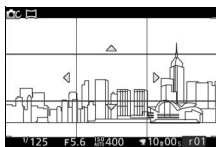



3 Pan the camera.

Slowly pan the camera up, down, left, or right as shown below. Shooting will start when the camera detects the pan direction and a progress indicator will appear in the display. Shooting ends automatically when the end of the panorama is reached.

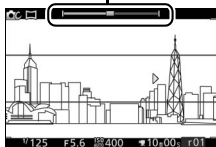
Progress indicator



An example of how to pan the camera is shown below. Without changing your position, pan the camera in a steady curve either horizontally or vertically. Time the pan according to the option selected for **Image size** in the shooting menu: about 15 seconds are needed to complete the pan when  **Normal panorama** is selected, about 30 seconds when  **Wide panorama** is selected.

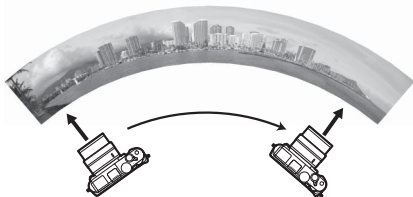



Panoramas

High-distortion wide-angle lenses may fail to produce the desired results. An error message will be displayed if the camera is panned too quickly or unsteadily. Note that because panoramas are composed of multiple images, the joins between images may be visible and the desired results may not be achieved with moving subjects or with neon lights or other subjects that exhibit rapid changes in color or brightness, subjects that are too close to the camera, poorly-lit subjects, and subjects such as the sky or sea that are a solid color or contain simple repeating patterns.







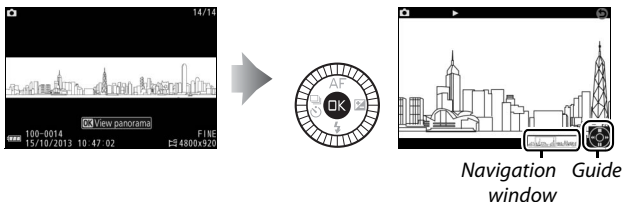

The completed panorama will be slightly smaller than the area visible in the display during shooting. No panorama will be recorded if shooting ends before the halfway point; if shooting ends after the halfway point but before the panorama is complete, the unrecorded portion will be shown in gray.

■ Viewing Panoramas

Panoramas can be viewed by pressing  when a panorama is displayed full frame ( 41). The start of the panorama will be displayed with the smallest dimension filling the display and the camera will then scroll through the picture in the original pan direction.



The following operations can be performed:

To	Use	Description
Pause		Pause playback.
Play		Resume playback when the panorama is paused or during rewind/advance.
Advance/ rewind	 	Press  to rewind,  to advance. If playback is paused, the panorama rewinds or advances a segment at a time; keep the button pressed for continuous rewind or advance. You can also rotate the multi selector to rewind or advance when playback is paused.
Return to full-frame playback		Press  or  to exit to full-frame playback.

Selective Color

Take black-and-white pictures in which one hue appears in a color.

1 Choose **Select color**.

Press **F** (feature) to display the **F** menu, then highlight **Select color** and press **OK**.

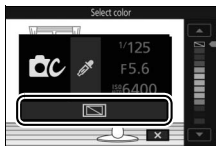

2 Choose a color.

Use the multi selector to choose a color and press **OK**.

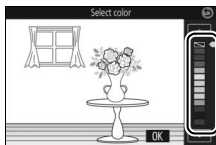

3 Take pictures.

Press the shutter-release button all the way down to take pictures. Only the selected hue will appear in color; all other hues will be recorded in shades of gray.

Cross Process

Select a base hue to take pictures with modified colors.

1 Select Hue.

Press **F** (feature) to display the **F** menu, then highlight **Hue** and press **OK**.

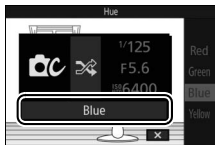

2 Choose a color.

Use the multi selector to choose a base color (red, green, blue, or yellow) and press **OK**.

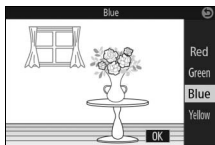

3 Take pictures.

Press the shutter-release button all the way down to take pictures with modified colors.



Recording and Viewing Movies

Recording Movies

Movies can be recorded using the movie-record button.

1 Turn the camera on.

Rotate the power switch to turn the camera on.

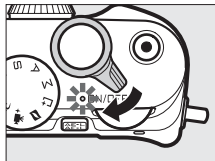

2 Choose a shooting mode.

Rotate the mode dial to (auto), (creative), P, S, A, M, or (advanced movie) as described on page 8. In advanced movie mode, you can choose a movie type using the **Advanced movie** option in the menu (□ 62).

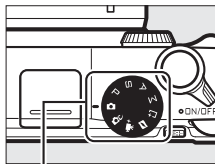

Mode dial

3 Frame the opening shot.

Frame the opening shot with your subject in the center of the display. If **Slow motion** is selected in advanced movie mode (□ 62), press the shutter-release button halfway to focus.

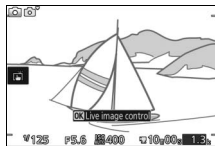

The Icon

A icon indicates that movies can not be recorded.

4 Start recording.

Press the movie-record button to begin recording. A recording indicator, the time elapsed, and the time available are displayed while recording is in progress.

Audio Recording

Be careful not to cover the microphone and note that the built-in microphone may record sounds made by the camera or lens. Except when recording slow-motion movies, the camera focuses continuously; to avoid recording focus noise, select **Single AF** for **Focus mode** in the movie menu (□ 99).

Focus and Exposure Lock

Focus and exposure will lock while the AF-L button is pressed (□ 214, 216).

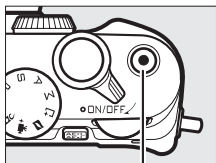

Movie-record button

*Recording indicator/
Time elapsed*



Time available

5 End recording.

Press the movie-record button again to end recording. Recording will end automatically when the maximum length is reached (□ 192), the memory card is full, another mode is selected, the lens is removed, or the camera becomes hot (□ xvii).

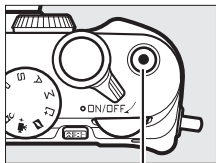

Movie-record button

Maximum Length

The camera can record movies up to 4 GB in size (for more information, see page 192); note that depending on memory card write speed, shooting may end before this length is reached (□ 224).

■ Shooting Mode

Movies can be recorded in the shooting modes listed below. Movies can not be recorded in best moment capture or Motion Snapshot modes.

 **Auto mode** (□ 38) —
Choose this mode to leave the camera in charge of choosing settings. The camera automatically adjusts settings according to the subject and situation.

 **Creative mode** (□ 49) —
*Record movies in exposure mode P (programmed auto). If **Creative Palette** is selected, the chosen effect will be applied to the movie (□ 52).*

 **Advanced movie mode** (□ 62) —
Choose an exposure mode (□ 170) and adjust shutter speed or aperture, or record movies in slow or fast motion or with other special effects.

P, S, A, and M modes (□ 69) —
Movies shot when S, A, or M is selected are recorded in exposure mode P. Exposure mode selection is available only in advanced movie mode.

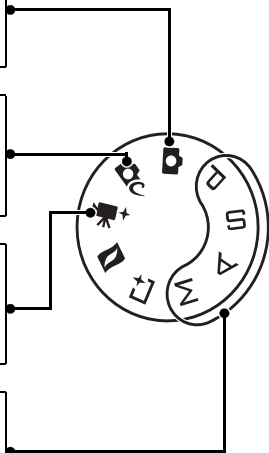

 **Movie Sound**
The **Movie sound options** item in the movie menu offers microphone sensitivity and wind noise options for both built-in and external microphones (□ 193).









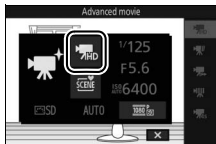

 **Available Settings**
For information on the options available in advanced movie mode, see page 232.



■ Advanced Movie Options

In **+** (advanced movie) mode, the following options can be accessed by pressing **F** (feature) and selecting **Advanced movie** in the **F** menu.



 HD movie	Record high-definition (HD) movies.
 Slow motion	<p>Record up to about three seconds of silent slow-motion footage. Slow-motion movies are recorded at 400 fps and play back at about 30 fps.</p> <p><i>Recording</i> </p> <p><i>Playback</i> </p>
 Fast motion	<p>Record silent fast-motion footage that plays back at about four times normal speed. Playback time is one quarter the recording time.</p> <p><i>Recording</i> </p> <p><i>Playback</i> </p>
 Jump cut	<p>Record silent jump-cut movies. Recording pauses every other second for a drop-frame effect.</p> <p><i>Recording</i> </p> <p><i>Playback</i> </p>
 4-second movie	Record a 4-second movie clip. Multiple clips can be joined into a single movie using the Combine 4-second movies option in the playback menu (□ 165).

The **F** (Feature) Menu 12

Pressing **F** in advanced movie mode displays the items listed below. The items available vary with the type of movie selected ( 62).

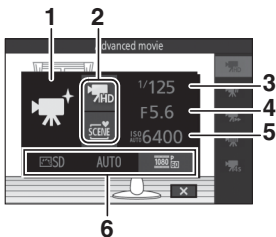

1	Shooting mode	8
2	Advanced movie.....	62
	Exposure mode.....	170
3	Shutter speed.....	71, 73
4	Aperture	72, 73
5	ISO sensitivity.....	201
6	Picture Control.....	202
	White balance	196
	Frame size/frame rate	192
	Slow motion	191

Slow Motion

When slow motion is selected in advanced movie mode, the camera can be focused by pressing the shutter-release button halfway before recording begins. The camera focuses on the subject at the center of the display; face detection ( 45) is not available. Focus and exposure can not be adjusted during recording. Frame rate options are described on page 191.

Recording Time

The following table lists the approximate maximum recording times for individual movies shot at the default frame size and rate in each shooting mode.

Auto, creative, P, S, A, and M modes	10 minutes
Advanced movie mode	
HD movie	10 minutes
Slow motion	3 seconds
Fast motion	20 minutes
Jump cut	20 minutes
4-second movie	4 seconds



Taking Photographs During Movie Recording

Press the shutter-release button all the way down to take a photograph without interrupting movie recording. Photographs taken during movie recording have an aspect ratio of 3 : 2.

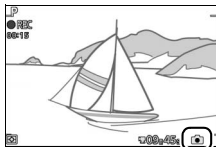



Taking Photographs During Movie Recording

Up to 20 photographs can be taken with each movie shot. Please note that photographs can not be taken with slow-motion movies.

See Also

See page 194 for information on configuring the camera to take photographs automatically during movie recording.

Viewing Movies

Movies are indicated by a  icon in full-frame playback (41). Press  to start playback.

 icon/Length



Movie playback indicator/
Current position/total length











Volume

Guide

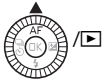

The following operations can be performed:

To	Use	Description
Pause		Pause playback.
Play		Resume playback when the movie is paused or during rewind/advance.
Advance/ rewind		Press  to rewind,  to advance. Speed increases with each press, from 2x to 4x to 8x to 16x. If playback is paused, the movie rewinds or advances one frame at a time; keep the button pressed for continuous rewind or advance. You can also rotate the multi selector to rewind or advance when playback is paused.
Adjust volume		Rotate the main command dial to adjust volume.
Return to full-frame playback		Press  or  to exit to full-frame playback.

The **F** (Feature) Menu (📖 12)

The following options can be accessed by pressing **F** when a movie is displayed:

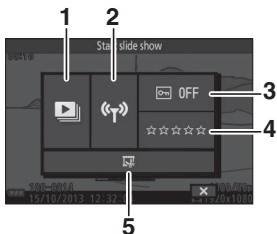

1 Start slide show	138
2 Wi-Fi upload	125
3 Protect	159
4 Rating.....	160
5 Edit movie.....	163

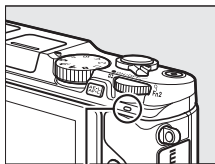

The Speaker

Keep your fingers and other objects away from the speaker when adjusting the volume.



Speaker

Deleting Movies

To delete the current movie, press . A confirmation dialog will be displayed; press  again to delete the movie and return to playback, or press  to exit without deleting the movie. *Note that once deleted, movies can not be recovered.*

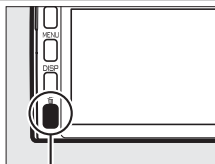

 button

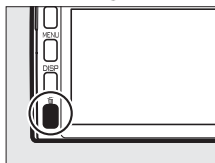

 **See Also**

See page 163 for information on trimming unwanted footage from movies. For information on the frame size and frame rate options available for HD movies, see page 192.

 **Recording Movies**

Flicker, banding, or distortion may be visible in the display and in the final movie under fluorescent, mercury vapor, or sodium lamps or if the camera is panned horizontally or an object moves at high speed through frame (flicker and banding can be reduced by choosing a **Flicker reduction** option that matches the frequency of the local AC power supply as described on page 217, but note that the slowest shutter speed available is $\frac{1}{100}$ s at **50 Hz**, $\frac{1}{60}$ s at **60 Hz**; flicker reduction is not available with slow-motion movies). Bright light sources may leave after-images when the camera is panned. Jagged edges, color fringing, moiré, and bright spots may also appear. When recording movies, avoid pointing the camera at the sun or other strong light sources. Failure to observe this precaution could result in damage to the camera's internal circuitry. The built-in flash and optional flash units will not fire during movie recording or when the camera is in advanced movie mode.

P, S, A, and M Modes

P, S, A, and M modes offer varying degrees of control over shutter speed and aperture. Choose a mode and adjust settings according to your creative intent.

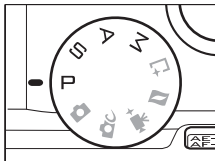

The **F** (Feature) Menu (☐ 12)

Pressing **F** in mode P, S, A, or M displays the items listed below.

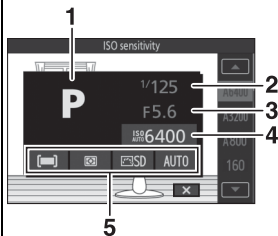

1	Shooting mode.....	8
2	Shutter speed.....	71, 73
3	Aperture	72, 73
4	ISO sensitivity.....	201
5	AF-area mode.....	185
	Metering	177
	Picture Control.....	202
	White balance	196

Available Settings

For information on the options available in P, S, A, and M modes, see page 234.

ISO Sensitivity (P, S, A, and M Modes)

When an “auto” option is selected for **ISO sensitivity** (☐ 201), the camera will automatically adjust sensitivity within the selected range if optimal exposure can not be achieved at the selected shutter speed or aperture.

Programmed Auto

In this mode, the camera automatically adjusts shutter speed and aperture for optimal exposure in most situations. This mode is recommended for snapshots and other situations in which you want to leave the camera in charge of shutter speed and aperture.

Choosing a Combination of Shutter Speed and Aperture

Although the shutter speed and aperture chosen by the camera will produce optimal results, you can also choose from other combinations that will produce the same exposure ("flexible program"). Rotate the main command dial right for large apertures (low f-numbers) that blur background details or fast shutter speeds that "freeze" motion. Rotate the dial left for small apertures (high f-numbers) that increase depth of field or slow shutter speeds that blur motion. * is displayed while flexible program is in effect.

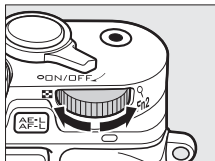

Main command dial

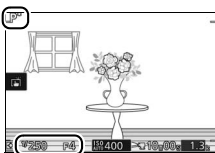

Restoring Default Shutter Speed and Aperture Settings

To restore default shutter speed and aperture settings, rotate the main command dial until * is no longer displayed or turn the camera off. The default shutter speed and aperture is automatically restored when the camera enters standby mode.

S Shutter-Priority Auto

In shutter-priority auto, you choose the shutter speed while the camera automatically selects the aperture that will produce the optimal exposure. Use slow shutter speeds to suggest motion by blurring moving subjects, fast shutter speeds to “freeze” motion.



Fast shutter speed ($1/1600$ s)

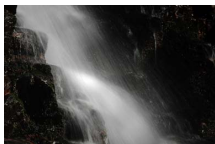

Slow shutter speed (1 s)

Choosing a Shutter Speed

Rotate the main command dial right for faster shutter speeds, left for slower shutter speeds. Choose from values between 30 s and $1/4000$ s. The electronic shutter, which can be enabled either by selecting **On** for **Silent photography** in the setup menu (☞ 212) or by choosing a frame rate of 10, 20, 30, or 60 fps in continuous shooting mode (☞ 92), supports shutter speeds as fast as $1/16,000$ s; the slowest shutter speed available with the electronic shutter is 30 s (silent photography) or $1/60$ s (10, 20, 30, and 60 fps continuous).

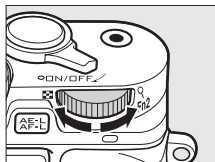

Main command dial

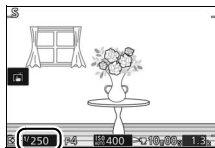

Continuous Shooting

The selected shutter speed may change when a frame rate of 10 fps or faster is selected in continuous shooting mode (☞ 92).

A Aperture-Priority Auto

In aperture-priority auto, you choose the aperture while the camera automatically selects the shutter speed that will produce the optimal exposure. Large apertures (low f-numbers) reduce depth of field, blurring objects behind and in front of the main subject. Small apertures (high f-numbers) increase depth of field, bringing out details in the background and foreground. Short field depths are generally used in portraits to blur background details, long field depths in landscape photographs to bring the foreground and background into focus.



Large aperture (f/5.6)



Small aperture (f/16)

■ ■ Choosing an Aperture

Aperture is selected by rotating the sub-command dial: choose from values between the minimum and maximum for the lens.

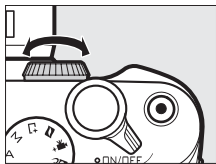

Sub-command dial

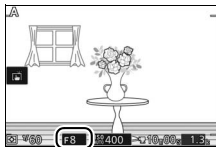

In manual mode, you control both shutter speed and aperture.

■ ■ Choosing Shutter Speed and Aperture

Adjust shutter speed and aperture with reference to the exposure indicator (📖 74). Shutter speed is set by rotating the main command dial right for faster speeds and left for slower speeds: choose from values between 30 s and $\frac{1}{4000}$ s (30 s and $\frac{1}{16,000}$ s when the electronic shutter is enabled by selecting **On** for **Silent photography** in the setup menu (📖 212), or $\frac{1}{60}$ s and $\frac{1}{16,000}$ s when the electronic shutter is enabled by selecting a frame rate of 10, 20, 30, or 60 fps in continuous shooting mode; 📖 92), or select “Bulb” to hold the shutter open indefinitely for a long time-exposure. Aperture is selected by rotating the sub-command dial: choose from values between the minimum and maximum for the lens.

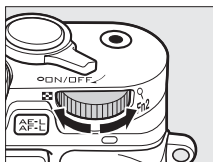

Main command dial

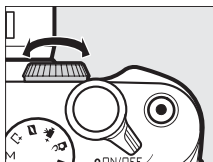

Sub-command dial

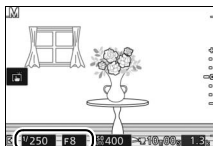

📌 Continuous Shooting

The selected shutter speed may change when a frame rate of 10 fps or faster is selected in continuous shooting mode (📖 92).

The Exposure Indicator

When shutter speeds other than “Bulb” or “Time” are selected, the exposure indicator shows whether the photograph would be under- or over-exposed at current settings.

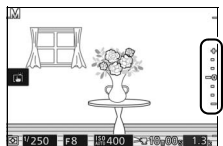

Optimal exposure	Underexposed by $\frac{1}{3}$ EV	Overexposed by over 2 EV
+ . . -o . . -	+ . . =o . . -	+ -o . . .

PS
AM

Long Time-Exposures (M Mode Only)

Select the following shutter speeds for long time-exposures of moving lights, the stars, night scenery, or fireworks.

- **Bulb:** The shutter remains open while the shutter-release button is held down.
- **Time:** Requires an optional ML-L3 remote control (☞ 96). Start the exposure by pressing the ML-L3 shutter-release button. The shutter remains open until the button is pressed a second time.



1 Ready the camera.

Mount the camera on a tripod or place it on a stable, level surface. To prevent loss of power before the exposure is complete, use a fully charged battery or an optional AC adapter and power connector. Note that noise (bright spots, randomly-spaced bright pixels, or fog) may be present in long exposures; before shooting, choose **On** for **Long exposure NR** in the shooting menu (☞ 180).

2 Choose a shutter speed.

Select mode M and choose a shutter speed as follows:

- **Bulb:** Rotate the main command dial left until “Bulb” is selected for shutter speed.
- **Time:** Rotate the main command dial left until “Bulb” is selected for shutter speed, and then press ◀ (Ⓢ) and select a remote control mode (📖 96).

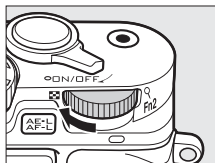

Main command dial

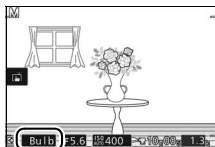

3 Open the shutter.

Bulb: After focusing, press the shutter-release button all the way down. Keep the shutter-release button pressed until the exposure is complete.

Time: Press the ML-L3 shutter-release button all the way down. The shutter will open immediately or after a two-second delay.



4 Close the shutter.

Bulb: Take your finger off the shutter-release button.



Time: Press the ML-L3 shutter-release button all the way down.

Shooting ends automatically after about two minutes. Note that some time may be required to record long exposures.

Other Shooting Modes

In addition to the modes described above, the camera offers  (best moment capture) mode to help with hard-to-time shots and a  (Motion Snapshot) mode that combines photographs with brief movie vignettes ( 87).

Choosing the Moment (Best Moment Capture)

Choose a shot from 40 frames recorded to temporary storage shortly before or after the shutter is released (Active Selection), choose the moment to release the shutter as the scene plays back in slow motion (slow view,  80), or let the camera choose the best shot based on composition and movement (Smart Photo Selector,  82).

Choosing a Shot Manually (Active Selection)

Choose up to 40 shots from 40 frames recorded shortly before or after the shutter-release button is pressed all the way down.

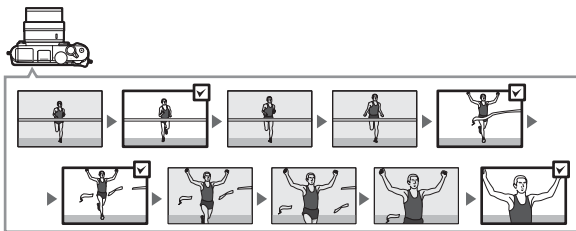

1 Select mode.

Rotate the mode dial to  (best moment capture).

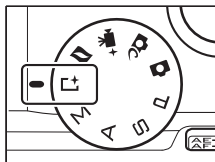

2 Choose Active Selection.

Press **F** (feature) to display the **F** menu. Highlight **Best moment capture** and press **OK**, then highlight **Active Selection** and press **OK**.

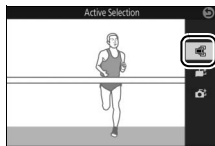
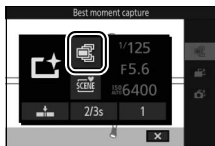

3 Frame the photograph.

Compose the photograph with your subject in the center of the frame.

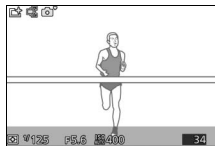

4 Begin buffering photographs.

Press the shutter-release button half-way to focus (see 39). A  icon will be displayed as the camera begins recording images to the memory buffer.

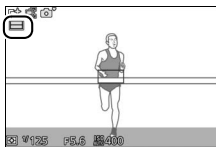







5 Shoot.

Smoothly press the shutter-release button the rest of the way down. The 40 frames recorded to the buffer in the moments before and after the shutter-release button was pressed all the way down will be copied to temporary storage.



6 Select up to 40 frames.

Press  or  or rotate the multi selector to scroll through the frames and press  or  to select or deselect. Selected images are indicated by a  icon, while the remaining images are marked with  icons to show that they will be deleted.

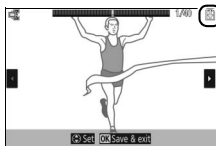

7 Save the selected frames.

Press **OK** to save the selected frames to the memory card. The memory card access lamp will light while recording is in progress; note that depending on shooting conditions and memory card write speed, some time may be required to save the selected images.

Active Selection

At default settings, the frame recorded at the moment the shutter-release button was pressed all the way down is automatically marked with a **AS** icon in Step 6.

The **F** (Feature) Menu (p. 12)

Pressing **F** in best moment capture mode displays the items listed below. The items available vary with the mode selected (p. 76, 80, 82).

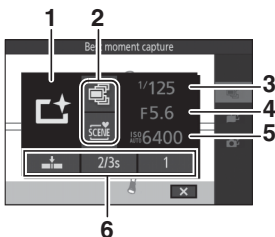

1	Shooting mode.....	8
2	Best moment capture	76
	Exposure mode.....	170
3	Shutter speed.....	71, 73
4	Aperture	72, 73
5	ISO sensitivity.....	201
6	On release, record	174
	Capture 40 frames over	174
	Frames saved (default).....	174
	Number of shots saved.....	175

Available Settings

For information on the options available in best moment capture mode, see page 232.

Best Moment Capture Mode

Movies can not be recorded, and pressing the movie-record button has no effect. The built-in flash and optional flash units can not be used.

See Also

See page 174 for information on adjusting settings for Active Selection.



Choosing Your Moment (Slow View)

When slow view is selected in  (best moment capture) mode, the camera captures a short sequence of still images and plays them back in slow motion so that you can choose the precise moment for a photograph.

1 Select mode.

Rotate the mode dial to  (best moment capture).

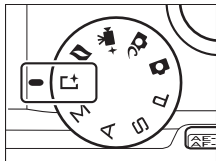

2 Select Slow view.

Press **F** (feature) to display the **F** menu. Highlight **Best moment capture** and press **OK**, then highlight **Slow view** and press **OK**.

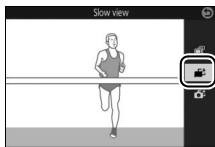

3 Frame the photograph.

Compose the photograph with your subject in the center of the frame.

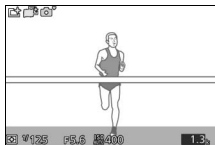

4 Press the shutter-release button halfway.

After focusing, the camera will record 40 frames to a temporary memory buffer. It will then slowly play them back in a continuous loop while the shutter-release button is kept pressed halfway. A  icon is displayed in the monitor.



Progress indicator



When the desired frame is displayed, press the shutter-release button the rest of the way down to record the current frame and discard the remaining images. The selected frame will be displayed for a few seconds when recording is complete. To delete the buffer contents and exit without recording a photograph, release the button without pressing it the rest of the way down.

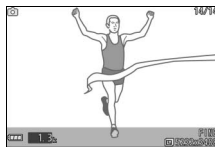

Letting the Camera Choose the Moment (Smart Photo Selector)

The Smart Photo Selector helps you capture a fleeting expression on the face of a portrait subject or other hard-to-time shots such as group photos in party scenes. Each time the shutter is released, the camera automatically selects the best shot and four best shot candidates based on composition and motion.



1 Select $\square+$ mode.

Rotate the mode dial to $\square+$ (best moment capture).

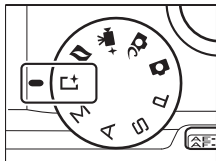

2 Choose Smart Photo Selector.

Press **F** (feature) to display the **F** menu. Highlight **Best moment capture** and press **OK**, then highlight **Smart Photo Selector** and press **OK**.

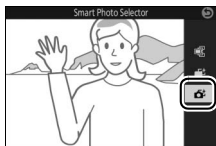
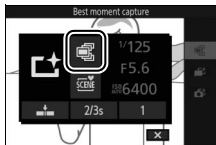

3 Frame the photograph.

Compose the photograph with your subject in the center of the frame.



4 Begin buffering photographs.

Press the shutter-release button half-way to focus (☞ 39). A  icon will be displayed as the camera begins recording images to the memory buffer. The camera continuously adjusts focus to account for changes in the distance to the subject while the shutter-release button is pressed halfway.

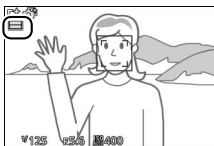

5 Shoot.

Smoothly press the shutter-release button the rest of the way down. The camera will compare shots recorded to the buffer both before and after the shutter-release button was pressed all the way down, and select five to copy to the memory card. Note that some time may be required. The best picture is displayed in the monitor when recording is complete.



Smart Photo Selector

The camera automatically chooses a scene mode appropriate to the subject.

Buffering

Buffering begins when the shutter-release button is pressed halfway and ends after about 90 seconds or when the shutter-release button is pressed all the way down.

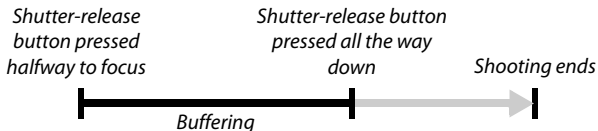



Smart Photo Selector Files

Do not delete the "NCSPSLST.LST" file from the "NCFL" folder on the memory card or change the file names of images taken with the Smart Photo Selector. The camera will no longer recognize the affected files as Smart Photo Selector images and will instead handle them as independent photographs.

See Also



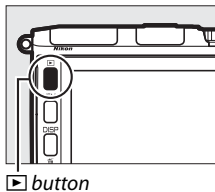

Use the **Number of shots saved** option in the shooting menu to choose the number of shots selected by the Smart Photo Selector (☞ 175).

■ Viewing Photos Taken with the Smart Photo Selector

Press  and use the multi selector to display photographs taken with the Smart Photo Selector (📖 41; pictures taken with the Smart Photo Selector are indicated by a  icon). Of the photographs recorded by the Smart Photo Selector, only the best shot will be displayed (when you press  to view the next picture, the camera will skip over the best shot candidates, with the result that the next picture displayed will not have a file number that immediately follows that of the current picture). To end playback and return to shooting mode, press the shutter-release button halfway.





Choosing the Best Shot

When a photograph taken with the Smart Photo Selector is displayed, you can choose the best shot by pressing . Press  or  to view the other pictures in the sequence and press  to select the current picture as the best shot. To return to normal playback, press .



■ Deleting Pictures

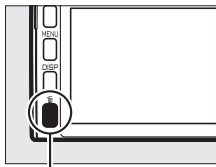

Pressing  when a picture taken with the Smart Photo Selector is selected displays a confirmation dialog; press  again to delete the best shot and the best shot candidates, or press  to exit without deleting the pictures. *Note that once deleted, pictures can not be recovered.*

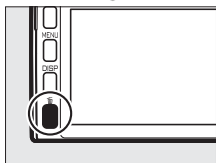

 button



Deleting Individual Photographs

Pressing the  button in the best shot selection dialog displays the following options; highlight an option using the multi selector and press  to select.

- **This image:** Delete the current photo (note that the picture currently selected as the best shot can not be deleted).
- **All except best shot:** Delete the best shot candidates, but not picture currently selected as the best shot.

A confirmation dialog will be displayed; to delete the selected image or images, highlight **Yes** and press .

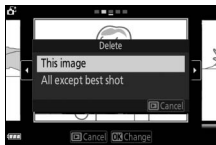

📷 Combining Photos with Brief Movie Vignettes (Motion Snapshot Mode)

Record brief movie vignettes with your photographs. Each time the shutter is released, the camera records a still image and about 1.6 s of movie footage. When the resulting “Motion Snapshot” is viewed on the camera, the movie will play back in slow motion over approximately 4 s, followed by the still image.

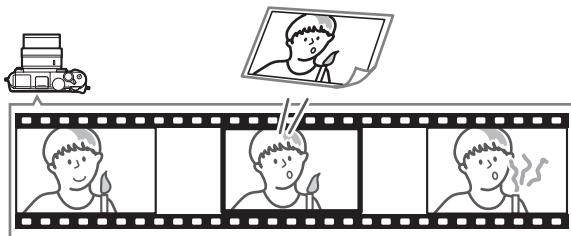

1 Select 📷 mode.

Rotate the mode dial to 📷 (Motion Snapshot).

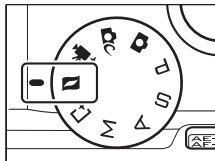

2 Frame the picture.

Compose the photograph with your subject in the center of the frame.



3 Begin buffering.

Press the shutter-release button half-way to focus (📖 39). A  icon will be displayed as the camera begins recording footage to the memory buffer.



4 Shoot.

Smoothly press the shutter-release button the rest of the way down. The camera will record a photograph, together with about 1.6 s of movie footage beginning before and ending after the time the shutter-release button was pressed all the way down. Note that some time may be required. When recording is complete, the photograph will be displayed for a few seconds.



Buffering

Buffering begins when the shutter-release button is pressed halfway and ends after about 90 seconds or when the shutter-release button is pressed all the way down.

*Shutter-release
button pressed
halfway to focus*

*Shutter-release button
pressed all the way
down*

Shooting ends



The **F** (Feature) Menu (📖 12)

Pressing **F** in Motion Snapshot mode displays the following items:

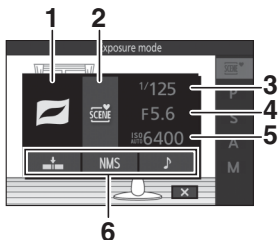

1	Shooting mode.....	8
2	Exposure mode.....	170
3	Shutter speed.....	71, 73
4	Aperture	72, 73
5	ISO sensitivity.....	201
6	Movie before/after	175
	File format.....	176
	Audio.....	90

Available Settings

For information on the options available in Motion Snapshot mode, see page 232.



■ Audio

To record about four seconds of sound with Motion Snapshots beginning at the start of movie recording, use the multi-selector and **OK** button to select **Ambient** for **Audio** in the **F** (feature) menu (89). Motion Snapshots can also be recorded with background music (**Background music**) or no sound (**None**).

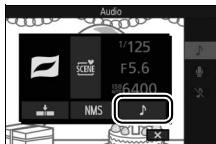





✎ Motion Snapshot Mode

Movies can not be recorded using the movie-record button and the built-in flash and optional flash units can not be used.

✎ See Also

See page 175 for information on choosing what portions of the buffer are included in the movie footage. For information on saving Motion Snapshots in a format that can be viewed in most movie playback software, see page 176. See page 166 for information on combining the movie portions of multiple Motion Snapshots into a single movie.

Viewing Motion Snapshots

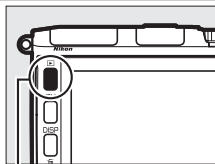

Press  and use the multi selector to display a Motion Snapshot ( 41; Motion Snapshots are indicated by a  icon). Pressing  when a Motion Snapshot is displayed plays back the movie portion in slow motion over a period of about 4 s, followed by the photo; playback is accompanied by the audio track selected using the **Audio** option ( 90). To end playback and return to shooting mode, press the shutter-release button halfway.



 button



Deleting Motion Snapshots

To delete the current Motion Snapshot, press . A confirmation dialog will be displayed; press  again to delete the photo and movie and return to playback, or press  to exit without deleting the file. *Note that once deleted, Motion Snapshots can not be recovered.*

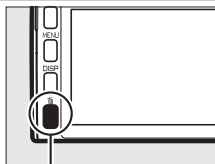

 button

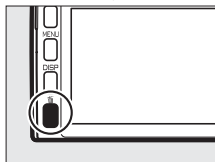
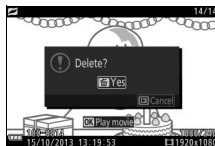

More on Photography

This section describes other features you can use when taking pictures.

Continuous Mode

Shoot a continuous series (burst) of photographs.

1 Display release mode options.

Press ◀ (📷) to display release mode options.



2 Select 📷.

Highlight 📷 (continuous) and press ▶ to display frame rate options.

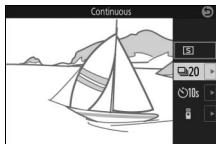

3 Select a frame rate.

Highlight the desired frame rate and press Ⓞ. Frame rate is expressed in terms of the number of frames recorded per second (fps); choose from frame rates of approximately 6, 10, 20, 30, and 60 fps (📷, 📷10, 📷20, 📷30, and 📷60, respectively). Except when 📷 is selected, the maximum number of shots that can be recorded in a single burst is 40.

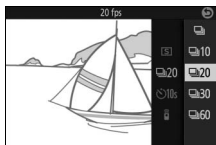



4 Frame your subject and shoot.

Press the shutter-release button all the way down to shoot the burst.



Continuous Mode

A mechanical shutter is used for pictures taken when  is selected and **Off** is selected for **Silent photography** in the setup menu (212). An electronic shutter is used for pictures taken at other settings. If the built-in flash or optional flash unit fires when  is selected, only one picture will be taken; at settings of 10, 20, 30, and 60 fps, the built-in flash and optional flash units will not fire.

While photographs are being recorded to the memory card, the memory card access lamp will light. Depending on shooting conditions and memory card write speed, recording may take some time. If the battery is exhausted before all photographs are recorded, the shutter release will be disabled and the remaining images transferred to the memory card.



Continuous shooting is not available in creative, best moment capture, advanced movie, or Motion Snapshot mode or when live image control is used in auto mode (47).

Buffer Size

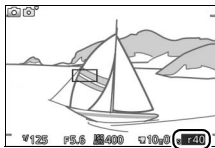
The camera is equipped with a memory buffer for temporary storage, allowing shooting to continue while photographs are being saved to the memory card. The approximate number of images that can be stored in the memory buffer at current settings is displayed while the shutter-release button is pressed halfway (this number is an approximation only and varies with shooting conditions). The illustration shows the display when space remains in the buffer for about 40 pictures.



Single Frame

To take only one picture each time the shutter-release button is pressed all the way down, press  and select  (single frame) for release mode.



Self-Timer Modes

The self-timer is used to delay shutter release until 10 or 2 seconds after the shutter-release button is pressed all the way down.

1 Display release mode options.

Press ◀ (📷) to display release mode options.



2 Select ⌚.

Highlight ⌚ (self-timer) and press ▶ to display self-timer options.



3 Select the desired self-timer option.

Use the multi selector to highlight ⌚10s or ⌚2s and press Ⓞ.

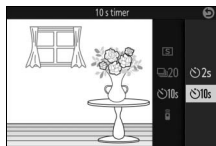

4 Mount the camera on a tripod.

Mount the camera on a tripod or place the camera on a stable, level surface.



5 Frame the photograph and shoot.

Press the shutter-release button half-way to focus, and then press the button the rest of the way down. The self-timer lamp will start to flash and a beep will begin to sound. Two seconds before the photo is taken, the lamp will stop flashing and the beeping will become more rapid.



Note that the timer may not start or a photograph may not be taken if the camera is unable to focus or in other situations in which the shutter can not be released. Turning the camera off cancels the self-timer.

Movie Mode

To record movies using the self-timer, select advanced movie mode and use the movie-record button to start the timer. Movie recording ends when the movie-record button is pressed a second time.

Raising the Flash

When using the built-in flash, press the flash pop-up button to raise the flash before shooting. Shooting will be interrupted if the flash is raised while the timer is counting down.

See Also

For information on controlling the beeps that sound when the self-timer is used, see page 212.



Remote Control Photography

The optional ML-L3 remote control (📖 222) can be used to reduce camera shake or for self-portraits.

Before Using the ML-L3 Remote Control

Before using the remote control for the first time, remove the clear plastic battery-insulator sheet.

1 Display release mode options.

Press ◀ (📷) to display release mode options.



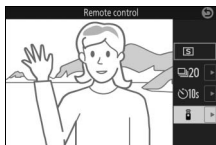

2 Select .

Highlight  (remote control) and press ▶ to display remote control options.



3 Select the desired remote-control option.

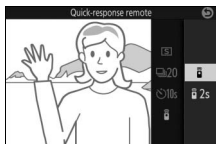

Use the multi selector to highlight  or  2s and press .



4 Mount the camera on a tripod.

Mount the camera on a tripod or place the camera on a stable, level surface.

5 Frame the photograph and shoot.

From a distance of 5 m (16 ft) or less, aim the ML-L3 at the infrared receiver on the front of the camera (📖 2) and press the ML-L3 shutter-release button. If  2s is selected, the self-timer lamp will light for about two seconds before the shutter is released. If  is selected, the self-timer lamp will flash after the shutter has been released.

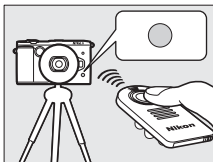

Note that the timer may not start or a photograph may not be taken if the camera is unable to focus or in other situations in which the shutter can not be released. Turning the camera off cancels remote control mode. Remote control mode is cancelled automatically if no operations are performed for about ten minutes after the mode is selected in Step 3.





Movie Mode

The ML-L3 shutter-release button functions as the movie-record button for advanced movie mode (📖 59).

Using a Flash

When using the built-in flash, press the flash pop-up button to raise the flash before shooting. Shooting will be interrupted if the flash is raised while the delayed-remote timer is counting down.

In remote control mode, the flash starts charging while the camera is waiting for the signal from the remote. The camera will only respond to the shutter-release button on the remote control when the flash is charged. If red-eye reduction (📖 106) is used when  is selected, the shutter will be released about one second after the red-eye reduction lamp lights. If  2s is selected, there will be about a two second delay after the shutter-release button on the remote control is pressed; the red-eye reduction lamp will then light for about one second before the shutter is released.



See Also

For information on choosing how long the camera will wait for a signal from the remote, see page 213.



Focus Mode

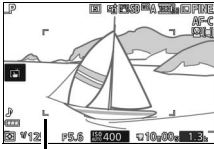





Choose how the camera focuses.



AF-A	Auto-select AF: The camera automatically selects AF-S if the subject is stationary, AF-C if it is moving.
AF-S	Single AF: For stationary subjects. Focus locks when the shutter-release button is pressed halfway. *
AF-C	<p>Continuous AF: For subjects in motion. The camera focuses continuously on the subject in the AF-area brackets while the shutter-release button is pressed halfway (note that the AF-area brackets appear only in the detailed display;  6). Photos can be taken whether or not the camera is in focus.</p>  <p style="text-align: right;"><i>AF-area brackets</i></p>
AF-F	Full-time AF: For subjects in motion. The camera focuses continuously; photos can be taken whether or not the camera is in focus.
MF	Manual focus: Focus manually ( 102). Photos can be taken whether or not the camera is in focus.

* Shutter can only be released if camera is able to focus.

Focus Mode

The focus modes available vary with the shooting mode as shown below.

Mode		Focus mode
P, S, A, M		AF-A (default), AF-S, AF-C, MF
Best moment capture	 Active Selection,  Slow view	AF-A (default), AF-S, AF-C, MF
Advanced movie mode	 HD movie,  Fast motion,	AF-F (default), AF-S, MF
	 Jump cut,  4-second movie  Slow motion	AF-S (default), MF

Focus mode can also be accessed from both the shooting ( 167) and movie ( 189) menus.



1 Display focus mode options.

Press ▲ (AF) to display focus mode options.



2 Select the desired option.

Use the multi selector to highlight the desired option and press .

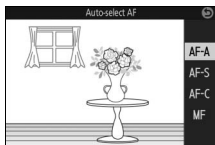

See Also

See page 212 for information on controlling the beep that sounds when the camera focuses.



Getting Good Results with Autofocus

Autofocus does not perform well under the conditions listed below. The shutter release may be disabled if the camera is unable to focus under these conditions, or the focus area may be displayed in green and the camera may sound a beep, allowing the shutter to be released even when the subject is not in focus. In these cases, focus manually (☐ 102) or use focus lock (☐ 216) to focus on another subject at the same distance, and then recompose the photograph.

There is little or no contrast between the subject and the background.

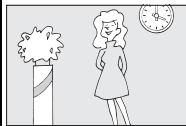

Example: The subject is the same color as the background.

The subject contains areas of sharply contrasting brightness.

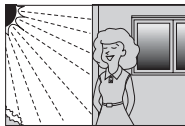

Examples: The subject is half in the shade; a night scene with point illumination.

The subject contains objects at different distances from the camera.



Example: The subject is inside a cage.

Background objects appear larger than the subject.



Example: A building is in the frame behind the subject.

The subject is dominated by regular geometric patterns.

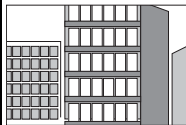

Example: Blinds or a row of windows in a skyscraper.

The subject contains many fine details or is made up of objects that are small or lack variation in brightness.

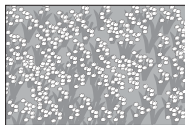

Example: A field of flowers.



Manual Focus

Manual focus can be used when autofocus does not produce the desired results.

1 Select manual focus.

Select **MF** (manual focus;  99).

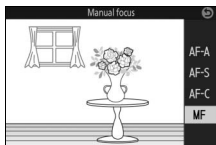

2 Display the manual focus guides.

In the shooting display, press  to magnify the view at the center of the frame (this feature is not available during movie recording or in slow-motion movie mode). Manual focus guides are also displayed.



3 Choose a magnification.

Rotate the main command dial to choose from magnifications of up to about 10x.

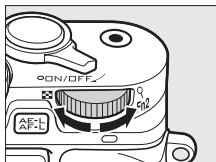

Main command dial

4 Focus.

Rotate the multi selector until the subject is in focus. Rotate the multi selector clockwise to increase the focus distance, counterclockwise to decrease; the faster you rotate the multi selector, the quicker the focus distance changes. The focus indicator shows the approximate focus distance. Press OK when the subject is in focus.

Press \blacktriangle , \blacktriangledown , \blacktriangleleft , or \blacktriangleright to view areas of the frame not currently visible in the display; the visible portion is shown by the navigation window.



Focus indicator

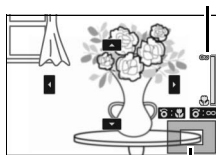

Navigation window

Movies

The multi selector can also be used to choose the focus distance if manual focus is selected prior to movie recording. Rotate the multi selector clockwise to increase the focus distance, counterclockwise to decrease; the faster you rotate the multi selector, the quicker the focus distance changes.

Focal Plane Position

To determine the distance between your subject and the camera, measure from the focal plane mark on the camera body. The distance between the lens mounting flange and the focal plane is approximately 17 mm (0.7 in.).

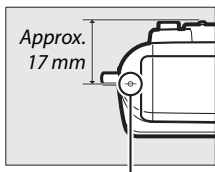

Focal plane mark



Exposure Compensation

Exposure compensation is used to alter exposure from the value suggested by the camera, making pictures brighter or darker.



-1 EV



No compensation



+1 EV

1 Display exposure compensation options.

Press **▶** () to display exposure compensation options.



2 Choose a value.

Use the multi selector to choose from values between -3 EV (underexposure) and $+3$ EV (overexposure) in increments of $\frac{1}{3}$ EV. In general, positive values make the image brighter while negative values make it darker.

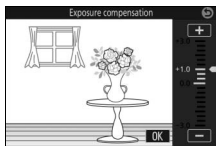

Normal exposure can be restored by setting exposure compensation to ± 0 . In modes **P**, **S**, and **A**, exposure compensation is not reset when the camera is turned off.

Exposure Compensation

Exposure compensation is most effective when used with center-weighted or spot metering ( 177).

Using a Flash

When used with a flash, exposure compensation affects both background exposure and flash level.

The Built-in Flash

Use the built-in flash for additional lighting when the subject is poorly lit or to “fill-in” (illuminate) back-lit subjects. The built-in flash can be used as described below, but note that some camera settings automatically disable the built-in flash:

1 Raise the flash.

Press the flash pop-up button to raise the flash.

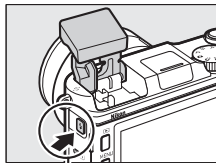

Flash pop-up button

2 Choose a flash mode.

Press ▼ (⚡) on the multi selector to display a list of flash modes, then use the multi selector to highlight the desired mode and press OK to select.

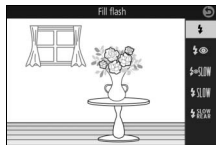













3 Take pictures.

The flash will fire with every shot. To disable the flash, press it gently downward until it latches.



■ Flash Modes

The following flash modes are available in  (auto),  (soft),  (miniature effect),  (selective color),  (cross process),  (toy camera effect), P, S, A, and M modes:

-  (fill flash): The flash fires with every shot.
-  (red-eye reduction): Use for portraits. The flash fires with every shot, but before it fires, the red-eye reduction lamp lights to help reduce “red-eye.”
-  SLOW (red-eye reduction with slow sync): As for “red-eye reduction”, above, except that shutter speed slows automatically to capture background lighting at night or under low light. Use when you want to include background lighting in portraits. Available only in modes P and A.
-  SLOW (fill flash + slow sync): As for “fill flash”, above, except that shutter speed slows automatically to capture background lighting at night or under low light. Use when you want to capture both subject and background. Available only in modes P and A.
-  SLOW REAR (rear curtain + slow sync): As for “rear-curtain sync”, below, except that shutter speed slows automatically to capture background lighting at night or under low light. Use when you want to capture both subject and background. Available only in modes P and A.
-  REAR (rear-curtain sync): The flash fires just before the shutter closes, creating a stream of light behind moving light sources as shown below at right. Available only in modes S and M.



Front-curtain sync



Rear-curtain sync

✓ Raising the Flash

When using the flash, be sure it is fully raised as shown at right. Do not touch the flash during shooting.

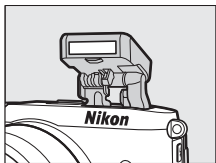

✎ Lowering the Built-in Flash

To save power when the flash is not in use, press it gently downward until the latch clicks into place. *Do not use force.* Failure to observe this precaution could result in product malfunction.

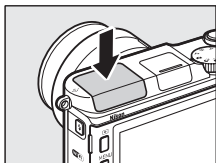

✎ The Flash-Ready Indicator

The flash-ready indicator (⚡) lights to show that the flash is fully charged when the shutter-release button is pressed halfway.



Using the Built-in Flash

If the flash is fired multiple times in quick succession, the flash and shutter may be temporarily disabled to protect the flash. Shooting can be resumed after a brief pause.

Objects close to the camera may be overexposed in photographs taken with the flash at high ISO sensitivities.

To avoid vignetting, remove lens hoods and shoot at ranges of at least 0.6 m (2 ft). Some lenses may cause vignetting at greater distances or obstruct the red-eye reduction lamp, interfering with red-eye reduction. The following illustrations show the effect of vignetting caused by shadows cast by the lens when the built-in flash is used.

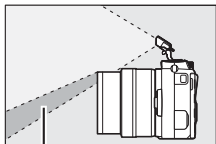

Shadow



Shadow

See Also

See page 187 for information on flash control, or page 188 for information on adjusting flash level.

Aperture, Sensitivity, and Flash Range

Flash range varies with sensitivity (ISO equivalency) and aperture.



Optional Flash Units

In still image mode, optional flash units for Nikon 1 cameras can be used for lighting effects such as bounce-flash photography. The built-in flash does not fire when an optional flash unit is attached.

In the instructions that follow, the optional SB-N7 flash unit is used for illustrative purposes.

Attaching Flash Units

Mount optional flash units on the camera multi accessory port.

1 Remove the multi accessory port cover.

Remove the cover as shown at right. Keep the cover in a safe place and replace it when the port is not in use.

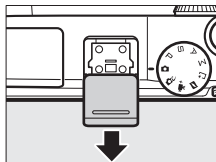

2 Attach the flash unit.

Turn the camera off and mount the flash unit on the multi accessory port as described in the manual provided with the flash unit.

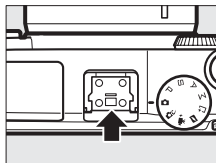

Supported Flash Units

The camera supports only flash units designated for use with Nikon 1 cameras.



Taking Pictures

Follow the steps below to take pictures with the flash.

1 Turn the camera and flash unit on.

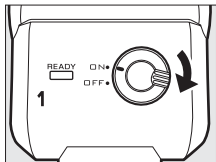

2 Choose a flash mode.

Choose a flash mode as described on page 105.

3 Position the flash head.

Rotate the flash head so that it points directly ahead.

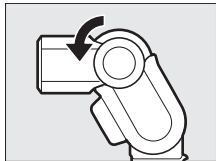

4 Take pictures.

Before shooting, confirm that the flash-ready light (flash status indicator) on the rear of the flash unit is lit and that the flash-ready indicator (⚡) appears in the camera display. To take pictures without the flash, turn the flash unit off.

Flash-ready light

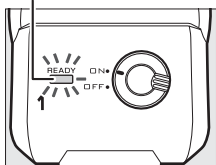

See Also

See page 187 for information on flash control, or page 188 for information on adjusting flash level.

■ Bounce Lighting

Light from the flash can be “bounced” (reflected) from a ceiling or wall, diffusing the light from the flash to make shadows less harsh and reduce glare from hair, skin, clothing and foreground objects.

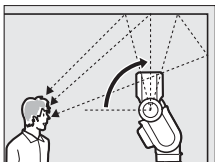

Flash head rotated upward 90°
(bounce lighting)

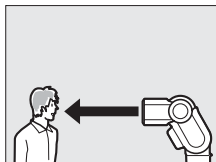

Flash pointed directly ahead
(normal lighting)

☑ Bounce Lighting

If possible, bounce flash lighting from a reflective white or near-white surface; light reflected from other surfaces may change the colors in the photograph. If no suitable surface can be found nearby, a piece of white paper (A4 or letter sized) can be used instead, but be sure to check the results in the camera display.

☑ The Capture Illuminator

The optional SB-N5 flash unit offers a capture illuminator that lights to illuminate subjects in best moment capture and Motion Snapshot modes (☞ 76, 87). In Active Selection, Smart Photo Selector, and Motion Snapshot modes, the illuminator will light for about 5 seconds during buffering, illuminating subjects about 1 m (3.3 ft) from the camera. In slow view, the illuminator will light for about 1.3 seconds, starting when the camera focuses after the shutter-release button is pressed halfway. Before shooting, confirm that the capture-illuminator status indicator is lit. The indicator also lights during buffering.

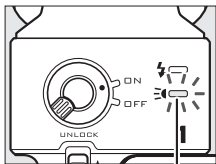

Capture-illuminator
status indicator



Optional Flash Units

Detailed instructions may be found in the manual provided with the flash unit. Note that optional flash units may not fire at some camera settings.

The Flash/Capture-Illuminator Status Indicators

Users of the SB-N5 are directed to check the table below if the flash status or capture-illuminator status indicator on the rear of the unit flashes. Users of the SB-N7 may refer to the manual provided with the flash unit.

Display	Description
The flash status indicator flashes for about 3 seconds after a photograph is taken.	Subject may be underexposed. Try again after reducing distance to subject or raising ISO sensitivity (☐ 201).
The flash or capture status indicator flashes once a second.	Product has fired several times in quick succession and has shut down temporarily to prevent overheating. Turn product off and wait for it to cool.
The flash and capture status indicators flash once every 2 seconds.	A data transfer error has occurred. Check that the flash unit is correctly attached.
The flash status indicator flashes 8 times a second.	An error has occurred in the unit's internal circuitry. Turn the camera off, remove the flash unit, and take the camera and flash unit to a Nikon-authorized service center for consultation.



The GP-N100 GPS Unit

GP-N100 GPS units (available separately) can be used to record information on your current position when pictures are taken. This information can be viewed on a computer using ViewNX 2 (supplied) or Capture NX 2 (available separately; □ 223). ViewNX 2 can be installed from the supplied ViewNX 2 CD.

Attaching the GP-N100

The GP-N100 attaches to the camera multi accessory port. Note that the built-in flash can not be used when the GP-N100 is attached.

1 Remove the multi accessory port cover.

Remove the cover as shown at right. Keep the cover in a safe place and replace it when the port is not in use.

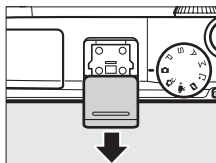

2 Attach the GP-N100.

Turn the camera off and mount the GP-N100 on the multi accessory port as described in the manual provided with the GPS unit.

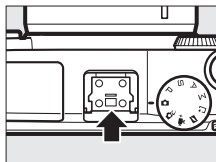

Setup Menu Options

The **Location data** item in the setup menu contains the following options. To display location data options, press **MENU** and select **Location data** in the setup menu.

- **Auto power off:** Choose whether the displays turn off automatically when the GP-N100 is attached.

Enable	Camera displays turn off automatically if no operations are performed for the time selected for Auto power off in the setup menu (☞ 213). This reduces the drain on the battery.
Disable	The displays do not turn off automatically while the GP-N100 is attached.

- **Position:** This item is only available if the GP-N100 is currently receiving location data, when it displays the current latitude, longitude, altitude, Coordinated Universal Time (UTC), and expiry date for Assisted GPS data (☞ 115) as reported by the GP-N100.





- **Set clock from satellite:** Select **Yes** to set the camera clock based on the time provided by the satellite navigation system.

Coordinated Universal Time (UTC)

UTC data is provided by the location data satellite system and is independent of the camera clock.

Connection Status

Connection status is shown by the satellite signal indicator in the camera display (□ 5) and the LED on the GP-N100:

Satellite signal indicator	LED	Description
	Flashes (red)	The GPS unit is searching for a signal. Pictures taken while the GPS unit is searching for a signal do not include location data.
	Flashes (green)	The unit is receiving signals from three satellites. Location data will be recorded with photographs.
	On (green)	The unit is receiving signals from four or more satellites. More precise location data will be recorded with photographs.

Location data are only recorded while the GP-N100 is receiving signals from at least three satellites. If no signal is received for over two seconds, the satellite signal indicator will clear from the camera display and no location data will be recorded.

Assisted GPS

When connected to a computer using its supplied USB cable, the GP-N100 can use resources provided by Nikon servers to reduce the time needed to acquire location data (location data can still be acquired without these resources, although the time needed to do may increase). This method of determining position using supplementary information stored in a file supplied by a network is known as "Assisted GPS" (A-GPS or aGPS). To connect to Nikon servers and receive Assisted GPS files, the GP-N100 uses GP-N100 Utility software, available for download from the following website:

<http://nikonimglib.com/gpn100u/>

For information on using GP-N100 Utility, see the above website or online help. The Assisted GPS file provided by the servers is valid for two weeks, after which time it can no longer be used to assist global positioning. Use GP-N100 Utility regularly to keep the GP-N100 up to date.



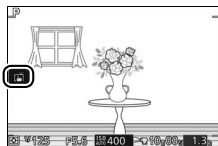

Tap Shooting Options

Tap the icon shown at right to choose the operation performed by tapping the monitor in shooting mode. The options available vary with the shooting and focus mode.



Auto and Creative Modes

Choose from the following options.





	When you tap a subject in the display, the camera will focus and take a picture.
	Tapping the display during shooting has no effect.

P, S, A, and M Modes

The operation performed by tapping the display depends on whether the camera is in autofocus or manual focus mode.



Autofocus Modes

The following options are available in autofocus modes (AF-A, AF-S, and AF-C).

	When you tap a subject in the display, the camera will focus and take a picture.
	Tap the display to position the focus area when single-point AF is selected for AF-area mode (□ 185). To focus, press the shutter-release button halfway.
	Tap a subject to start tracking when subject tracking is selected for AF-area mode (□ 185).
	Tapping the display during shooting has no effect.

Manual Focus Mode

The following options are available in manual focus mode.



	When you tap the display, the camera will take a picture without first adjusting focus.
	Tap a subject to display it at a higher magnification in the monitor (□ 102).
	Tapping the display during shooting has no effect.

Advanced Movie Mode

The operation performed by tapping the display depends on whether the camera is in autofocus or manual focus mode.

Autofocus Modes



The following options are available in autofocus modes (AF-F and AF-S).

	To focus when auto-area AF or single-point AF is selected for AF-area mode, tap your subject in the display.
	Tap a subject to start tracking when subject tracking is selected for AF-area mode (□ 185).
	Tapping the display during shooting has no effect.



Manual Focus Mode

The following options are available in manual focus mode.



	Tap a subject to display it at a higher magnification in the monitor (□ 102).
	Tapping the display during shooting has no effect.

Best Moment Capture/Motion Snapshot

Tap shooting options are not available in best moment capture and Motion Snapshot modes.

Taking Pictures Using Tap Shooting Options

Avoid tapping too hard. The camera may move when the shutter is released, blurring photographs.

The shutter-release button can be used to focus and take pictures even when the  icon is displayed to show that tap shooting options are active. Use the shutter-release button to take photographs in continuous shooting mode ( 92) and during movie recording. Tap shooting options can be used only to take pictures one at a time in continuous shooting mode and can not be used to take photographs during movie recording. In self-timer mode ( 94), tapping the monitor locks focus and starts the timer; the photograph will be taken after ten or two seconds.



Wi-Fi

What Wi-Fi Can Do for You

The camera can connect via Wi-Fi wireless networks to a smart device running Nikon's dedicated Wireless Mobile Utility app. The smart device can be used to control the camera and take pictures remotely, or pictures can be downloaded from the camera to the smart device and shared with others on the Internet. Pictures can also be uploaded from the camera to the smart device (📖 125).

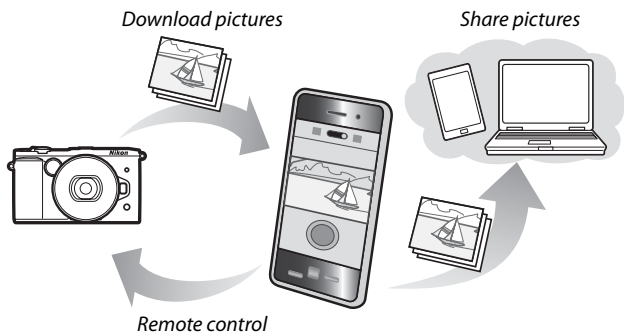

🔍 Installing the Wireless Mobile Utility App

1 Find the app.

On the smart device, connect to the Google Play service, the App Store, or another app marketplace and search for "Wireless Mobile Utility". For more information, see the instructions provided with the smart device.

2 Install the app.

Read the app description and install the app. A pdf manual for the Wireless Mobile Utility is available for download at the following URLs:

- **Android:** <http://nikonimglib.com/ManDL/WMAU/>
- **iOS:** <http://nikonimglib.com/ManDL/WMAU-ios/>

Accessing the Camera

Before connecting via Wi-Fi (wireless LAN), install the Wireless Mobile Utility on your Android or iOS smart device. Instructions for accessing the camera vary with the type of connection used by the smart device.

Android

- **Push-button WPS:** If the smart device supports push-button WPS (i.e., has a **WPS button connection** option in its **Wi-Fi settings** menu), you can use this easy method to connect to the smart device (📖 121)
- **PIN-entry WPS:** If the smart device supports WPS, you can use the camera to establish a connection by entering the PIN displayed by the smart device (📖 122)
- **View SSID:** If the smart device does not support WPS, you can connect by selecting the camera SSID on the smart device (📖 123)

iOS

- **View SSID:** Connect by selecting the camera SSID on the smart device (📖 123)



WPS

WPS (Wi-Fi Protected Setup) is a standard designed to make it easy to establish a secure wireless network. For information on the steps involved and the length of time the smart device will wait for a connection, see the documentation supplied with the smart device.

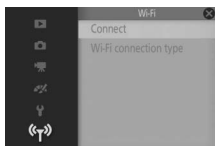

1 Select Wi-Fi.

Press the MENU button to display the menus, then highlight **Wi-Fi** and press .



2 Connect.

Enable WPS button connections on the camera and smart device:

- **Camera:** Highlight **Wi-Fi connection type** and press , then highlight **Push-button WPS** and press  to ready the camera for a WPS connection. The camera will wait about two minutes for a WPS connection request from the smart device. To extend the wait time, press .
- **Smart device:** Select **Wi-Fi settings** > **WPS button connection**.

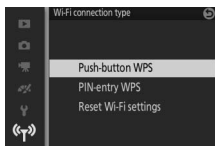
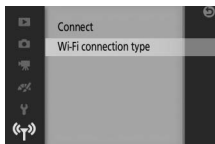

3 Launch the Wireless Mobile Utility.

Launch the Wireless Mobile Utility on the smart device. The main dialog will be displayed.

PIN Entry (Android Only)

1 Select Wi-Fi.

Press the MENU button to display the menus, then highlight **Wi-Fi** and press .

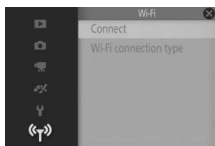

2 Select Wi-Fi connection type > PIN-entry WPS.



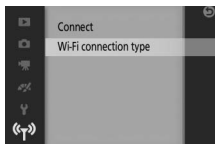

Highlight **Wi-Fi connection type** and press .

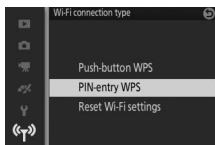

Highlight **PIN-entry WPS** and press .



3 Enter the PIN.

Enter the PIN displayed by the smart device. Press  or  to highlight digits and press  or  to change. Press  when entry is complete.

4 Launch the Wireless Mobile Utility.

Launch the Wireless Mobile Utility on the smart device. The main dialog will be displayed.

SSID (Android and iOS)

1 Select Wi-Fi.

Press the MENU button to display the menus, then highlight **Wi-Fi** and press **OK**.

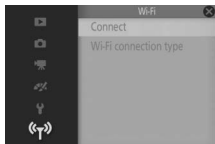

2 Select Connect.

Highlight **Connect** and press ►.

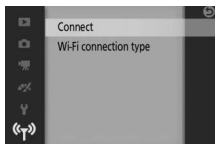

3 Select Yes.

Highlight **Yes** and press **OK** to view the camera SSID.



4 Select the camera SSID on the smart device.

Select the camera SSID in the list of networks displayed by the smart device.



5 Launch the Wireless Mobile Utility.

Launch the Wireless Mobile Utility on the smart device. The main dialog will be displayed.

■ Restoring Default Settings

To restore default network settings, highlight **Wi-Fi connection type** > **Reset Wi-Fi settings** and press ►. A confirmation dialog will be displayed; highlight **Yes** and press (OK) to restore default network settings.

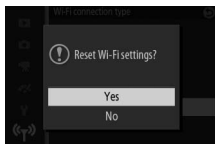

☑ Wi-Fi

Before using the Wi-Fi function, read the warnings on pages xix to xxi; to prevent loss of power while connected, you should also charge the camera battery. Do not use Wi-Fi in settings in which its use is prohibited. Note that the camera Wi-Fi function can not be used when a USB or HDMI cable is connected.

✍ Terminating Wi-Fi Connections

Wi-Fi will terminate automatically if the smart device does not initiate a connection within five minutes. To terminate Wi-Fi manually, press the MENU button to exit the Wi-Fi standby or connection display.

☑ Electronic Viewfinders

Optional electronic viewfinders (□ 34) turn off while Wi-Fi is in use. The eye sensor turns on automatically when the Wi-Fi connection ends.



Uploading Pictures to a Smart Device

Follow the steps below to upload photos from the camera to a smart device.

Uploading Photos One at a Time

Use the **Wi-Fi upload** option in the playback **F** (feature) menu (☰ 12) to upload the photo currently displayed in full-frame playback.

1 Display the photo on the camera.

Display the desired photo in full-frame playback.

2 Select Wi-Fi upload.

Press **F** (feature) to display the **F** menu, then highlight **Wi-Fi upload** and press **OK**. A confirmation dialog will be displayed.



3 Select Yes.

Highlight **Yes** and press **OK**. To upload multiple selected photos, choose **Select images from list** and proceed to Step 2 on page 127.

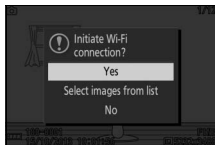

4 Select the camera SSID on the smart device.

Select the camera SSID in the list of networks displayed by the smart device.



5 Download the photo to the smart device.

Launch the Wireless Mobile Utility on the smart device and follow the on-screen instructions to download the photo. When download is complete, press the MENU button on the camera to terminate the Wi-Fi connection.



Uploading Multiple Selected Photos

To upload multiple selected photos, use the **Wi-Fi upload** option in the playback menu.

1 Choose **Wi-Fi upload**.

Press the MENU button to display the menus. Highlight **Wi-Fi upload** in the playback menu and press ►.

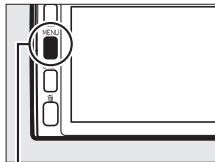

MENU button

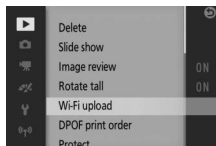

2 Select photos.

Press ◀ or ▶ to scroll through pictures and press ▲ or ▼ to select or deselect, or press and hold the main command dial (158) to view the highlighted picture full frame. Selected images are indicated by a  icon.

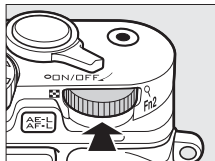
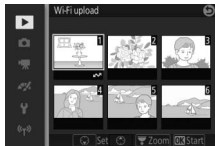

Main command dial



3 Press .

Press  to complete the operation. A confirmation dialog will be displayed.

4 Select **Yes**.

Highlight **Yes** and press .



5 Select the camera SSID on the smart device.

Select the camera SSID in the list of networks displayed by the smart device.

6 Download the photos to the smart device.

Launch the Wireless Mobile Utility on the smart device and follow the on-screen instructions to download the selected photos. When download is complete, press the MENU button on the camera to terminate the Wi-Fi connection.



More on Playback

Photo Information

Photo information is superimposed on images displayed in full-frame playback (☞ 41). Press the **DISP** button to cycle through simple photo information, detailed photo information, highlights, and no photo information (☞ 7). Highlights are only displayed if **On** is selected for the **Display > Playback highlight display** option in the setup menu (☞ 212).

■ Simple photo info

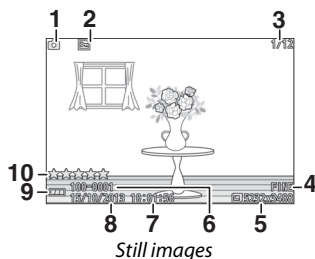

Still images

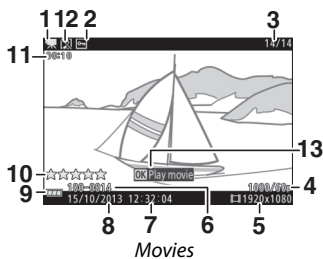

Movies

- | | |
|---------------------------------------|--|
| 1 Shooting mode | 6 Folder number-file number 131 |
| 2 Protect status 159 | 7 Time of recording 31, 218 |
| 3 Frame number/total number of images | 8 Date of recording 31, 218 |
| 4 Image quality 171 | 9 Battery indicator 33 |
| Frame rate 191, 192 | 10 Rating 137 |
| 5 Image size 172 | 11 Movie length 65 |
| Frame size 191, 192 | 12 Audio recording indicator 193 |
| | 13 On-screen guide (for movies) 65 |

▣ Thumbnail Playback

Press **DISP** to view or hide photo info when thumbnails are displayed (☞ 133).

■ Detailed photo info

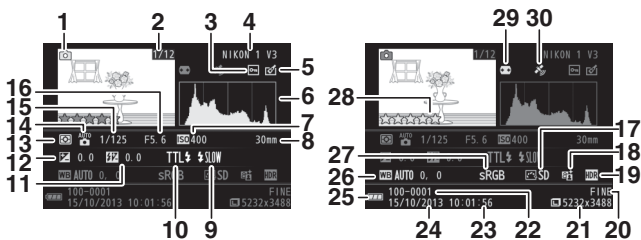

Still images

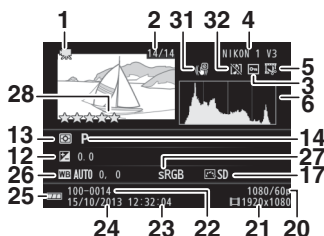

Movies

1 Shooting mode	13 Metering 177
2 Frame number/total number of images	14 Creative mode 49
3 Protect status..... 159	Exposure mode 170
4 Camera name	15 Shutter speed 71, 73
5 Retouch indicator 160, 161, 162	16 Aperture..... 72, 73
Movie edit indicator 163	17 Picture Control 202
6 Histogram showing distribution of tones in image 132	18 Active D-Lighting indicator..... 179
7 ISO sensitivity 201	19 HDR indicator 53
8 Focal length 254	20 Image quality 171
9 Flash mode 106	Frame rate 191, 192
10 Flash control..... 187	21 Image size..... 172
11 Flash compensation 188	Frame size..... 191, 192
12 Exposure compensation 104	

22	Folder number-file number	27	Color space.....	178	
23	Time of recording	31, 218	28	Rating	137
24	Date of recording	31, 218	29	Auto distortion control	178
25	Battery indicator	33	30	Location data indicator	113
26	White balance.....	196	31	Electronic VR.....	184
	White balance fine-tuning	197	32	Audio recording indicator	193

■ Highlights *

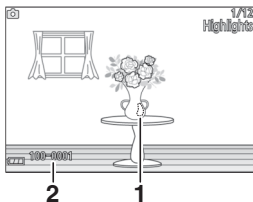

- 1 Image highlights
- 2 Folder number-file number

*Flashing areas indicate highlights (areas that may be overexposed).

📁 Folder and File Numbers

Photographs are stored as files with names containing a four-digit number between 0001 and 9999 assigned automatically in ascending order by the camera. These in turn are stored in folders containing up to 999 images. A new folder is created automatically when file numbering reaches 9999 or the number of images in the current folder reaches 999.

100-0001
 Folder number File number



Histograms (📖 130)

Camera histograms are intended only as a guide and may differ from those in imaging applications. Sample histograms are shown below:

- **If brightness varies evenly across the image**, the distribution of tones will be relatively even.



- **If the image is dark**, tone distribution will be shifted to the left.

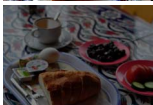

- **If the image is bright**, tone distribution will be shifted to the right.









Exposure compensation shifts the distribution of tones to the right when raised, to the left when lowered. Histograms can give you a rough idea of overall exposure when bright ambient lighting makes it difficult to see the display in the monitor.



Thumbnail Playback

To view pictures in “contact sheets” of 4, 9, or 16 images, rotate the main command dial left when a picture is displayed full frame.

The following operations can be performed:









To	Use	Description
Display more images		Rotate the main command dial left to increase the number of images displayed. To view images taken on selected dates (☞ 134), rotate the dial left when 16 images are displayed. 
Display fewer images		Rotate the main command dial right to decrease the number of images displayed. To view the highlighted image full frame, rotate the dial right when 4 images are displayed. 
Highlight images		Use the multi selector or sub-command dial to highlight images. You can delete (☞ 136) the highlighted image or zoom in for a closer look (☞ 135).
View highlighted image		Press OK to view the highlighted image full frame.
Delete highlighted image		See page 136.



Calendar Playback

To view pictures taken on a selected date, rotate the main command dial left when 16 pictures are displayed (☞ 133).







The following operations can be performed:

To	Use	Description
Display calendar		To view the calendar, rotate the main command dial left when 16 images are displayed (☞ 133). 
Exit to thumbnail playback		To return to the 16-image display, rotate the main command dial right when the calendar is displayed. 
Highlight date		Use multi selector or sub-command dial to highlight date in calendar display.
View pictures taken on highlighted date		Press  to view the first picture taken on the highlighted date.
Delete pictures taken on highlighted date		Press  to delete all pictures taken on the highlighted date.

Playback Zoom

To zoom in on a photograph, display it full frame and rotate the main command dial right. Playback zoom is not available with movies or Motion Snapshots.



The following operations can be performed:

To	Use	Description
Zoom in or out		Rotate the main command dial right to zoom in, left to zoom out. Whenever you zoom in or out, a navigation window will appear with the area currently visible in the display indicated by a yellow border. 
View other areas of image		Press ▲, ▼, ◀, or ▶ to scroll the image.
View faces		Faces (up to five) detected during face priority are indicated by white borders in the navigation window. Rotate the multi-selector or sub-command dial to view other faces. 
Exit zoom		Return to full-frame playback. 

Deleting Pictures

Pictures can be deleted from the memory card as described below. *Note that once deleted, pictures can not be recovered; protected images, however, will not be deleted.*

Deleting the Current Picture

To delete the picture currently displayed in full-frame playback or selected in the thumbnail list, press . A confirmation dialog will be displayed; press  again to delete the picture and return to playback, or press  to exit without deleting the picture.

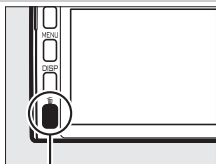



 button

The Playback Menu

To delete multiple images, press the MENU button, select **Delete** in the playback menu, and choose from the options below. A confirmation dialog will be displayed; select **Yes** to delete the images (note that some time may be required if a large number of images is selected).



Delete selected images	Highlight images and press ▲ or ▼ to select or deselect (□ 158). Press  to exit when the selection is complete.
Select images by date	Highlight dates and press ► to select or deselect. To view the pictures taken on the highlighted date, rotate the main command dial right; rotate the dial left to return to the date list. Press  to delete all pictures taken on the selected dates.
Delete all images	Delete all pictures on the memory card.

Rating Pictures

Rate pictures or mark them as candidates for later deletion. Rating is not available with protected images.

1 Select a picture.

Display a picture in full-frame playback.

2 Select Rating.

Press **F** (feature) to display the **F** menu. Highlight **Rating** and press **OK**.

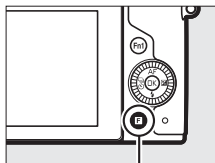

F button



3 Choose a rating.

Highlight a rating of from zero to five stars, or select **Not rated** to mark the picture as a candidate for later deletion. Press **OK** to select the highlighted rating.

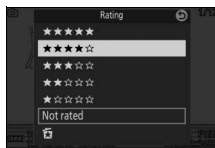

Slide Shows

To view a slide show of the pictures on the memory card, press the **MENU** button, select **Slide show** in the playback menu, and follow the steps below.

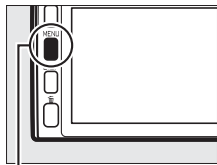

MENU button

1 Select the type of image used in the show.

Highlight the desired option and press ►.

All images	Display all the images on the memory card.
Still images	Display still images only. Images taken using Easy panorama will be displayed in panorama mode (□ 56).
Movies	Display movies and Motion Snapshots recorded with MOV file selected for File format (□ 176).
Motion Snapshot	Display Motion Snapshots recorded with NMS files selected for File format (□ 176). Only the movie portion will be played; the associated photographs are not displayed.
Select images by date	Display only images recorded on a selected date. A calendar will be displayed; use the multi-selector to highlight a date.

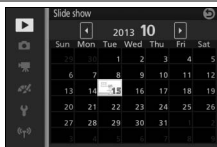

2 Adjust display times and audio settings.

Adjust the following options:



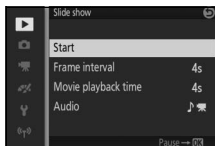

Frame interval	Choose how long each still image is displayed.
Movie playback time	Choose how much of each movie is played back before the next slide is displayed. Choose Same as frame interval to display the next slide after the time selected for Frame interval , No limit to play back the entire movie before displaying the next slide.
Audio	Mute audio playback, or select Movie sound tracks to play audio recorded with movies and with Motion Snapshots recorded with Ambient selected for Audio (□ 90). No sound is played for still images.

3 Select Start.

Highlight **Start** and press  to start the slide show.



The following operations can be performed while a slide show is in progress:

To	Use	Description
Skip back/skip ahead		Press ◀ to return to the previous frame, ▶ to skip to the next frame. You can also skip frames by rotating the multi selector or sub-command dial.
Pause/resume		Pause the show. Press again to resume.
Adjust volume		Rotate the main command dial to adjust volume.
Exit to playback mode		End the show and return to playback mode.

The options shown at right are displayed when the show ends. Select **Resume** to restart or **Exit** to exit to the playback menu.

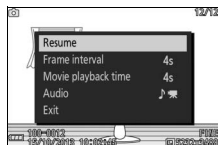

The Speaker

Keep your fingers and other objects away from the speaker when adjusting the volume.

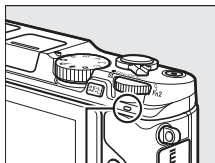

Speaker

Connections

Installing the Supplied Software

Install the supplied software to copy pictures to your computer for viewing and editing. Before installing the software, confirm that your system meets the requirements on page 143.

1 Launch the installer.

Start the computer, insert the ViewNX 2 installer CD, and launch the installer. A language-selection dialog will be displayed; if the desired language is not available, click **Region Selection** to choose a different region and then choose the desired language (region selection is not available in the European release).

① *Select region (if required)*



② *Select language*

③ *Click Next*

2 Start the installer.

Click **Install** and follow the on-screen instructions.

Click Install



3 Exit the installer.

Click **Yes** (Windows) or **OK** (Mac) when installation is complete.

Windows



*Click **Yes***

Mac

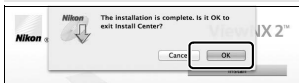

*Click **OK***

4 Remove the installer CD from the CD-ROM drive.

Supplied Software

Be sure to update to the latest versions of the supplied software. Nikon Message Center 2 will periodically check for updates while the computer is connected to the Internet.

Motion Snapshots

ViewNX 2 is required to view Motion Snapshots saved using the **File format > NMS files** option in the shooting menu (☞ 176).

Supported Operating Systems

See the websites listed on page xviii for the latest information on supported operating systems.



System Requirements

The system requirements for ViewNX 2 are:

Windows	
CPU	<ul style="list-style-type: none">• Photos: Intel Celeron, Pentium 4, Core Series; 1.6 GHz or better• Movies (playback): Pentium D 3.0 GHz or better; Intel Core i5 or better recommended when viewing movies with a frame size of 1280 × 720 or more at a frame rate of 30 fps or above or movies with a frame size of 1920 × 1080 or more• Movies (editing): Intel Core i5 or better
OS	Pre-installed versions of Windows 8.1, Windows 7, or Windows Vista
Memory (RAM)	<ul style="list-style-type: none">• 32-bit Windows 8.1, Windows 7, or Windows Vista: 1 GB or more (2 GB or more recommended)• 64-bit Windows 8.1, Windows 7, or Windows Vista: 2 GB or more (4 GB or more recommended)
Hard disk space	A minimum of 1 GB available on the startup disk (3 GB or more recommended)
Graphics	<ul style="list-style-type: none">• Resolution: 1024 × 768 pixels (XGA) or more (1280 × 1024 pixels or more recommended)• Color: 24-bit color (True Color) or more



Mac	
CPU	<ul style="list-style-type: none"> • Photos: Intel Core or Xeon series • Movies (playback): Core Duo 2 GHz or better; Intel Core i5 or better recommended when viewing movies with a frame size of 1280 × 720 or more at a frame rate of 30 fps or above or movies with a frame size of 1920 × 1080 or more • Movies (editing): Intel Core i5 or better
OS	OS X 10.9, 10.8, or 10.7
Memory (RAM)	2 GB or more (4 GB or more recommended)
Hard disk space	A minimum of 1 GB available on the startup disk (3 GB or more recommended)
Graphics	<ul style="list-style-type: none"> • Resolution: 1024 × 768 pixels (XGA) or more (1280 × 1024 pixels or more recommended) • Color: 24-bit color (millions of colors) or more



Viewing and Editing Pictures on a Computer

Transferring Pictures

1 Choose how pictures will be copied to the computer.

Choose one of the following methods:

- **Direct USB connection:** Turn the camera off and ensure that the memory card is inserted in the camera. Connect the camera to the computer using the supplied USB cable (do not use force or insert the connectors at an angle) and then turn the camera on.

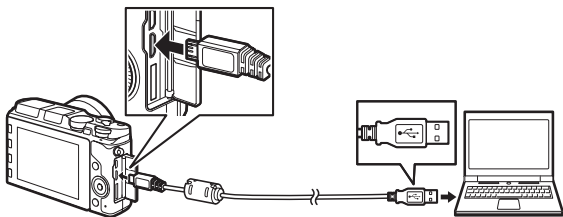

- **Card slot:** If your computer is equipped with a slot for microSD memory cards, the card can be inserted directly in the slot.
- **Card reader:** Connect a card reader (available separately from third-party suppliers) to the computer and insert the memory card.



2 Start the Nikon Transfer 2 component of ViewNX 2.

If a message is displayed prompting you to choose a program, select Nikon Transfer 2.

Windows 7

If the following dialog is displayed, select Nikon Transfer 2 as described below.

1 Under **Import pictures and videos**, click **Change program**. A program selection dialog will be displayed; select **Import File using Nikon Transfer 2** and click **OK**.

2 Double-click **Import file**.



3 Click Start Transfer.

At default settings, all the pictures on the memory card will be copied to the computer.



Click **Start Transfer**

4 Terminate the connection.

If the camera is connected to the computer, turn the camera off and disconnect the USB cable. If you are using a card reader or card slot, choose the appropriate option in the computer operating system to eject the removable disk corresponding to the memory card and then remove the card from the card reader or card slot.

Viewing Pictures

Pictures are displayed in ViewNX 2 when transfer is complete.

Starting ViewNX 2 Manually

- **Windows:** Double-click the ViewNX 2 shortcut on the desktop.
- **Mac:** Click the ViewNX 2 icon in the Dock.

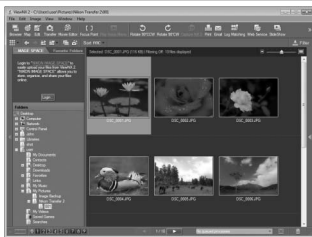

Retouching Photographs

To crop pictures and perform such tasks as adjusting sharpness and tone levels, click the **Edit** button in the toolbar.



Printing Pictures

Click the **Print** button in the toolbar. A dialog will be displayed, allowing you to print pictures on a printer connected to the computer.

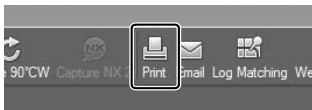

Viewing Location Data

To view the locations where pictures were taken (113), click the **Map** button in the ViewNX 2 toolbar (Internet connection required).



For More Information

Consult online help for more information on using ViewNX 2.

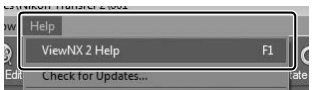

Viewing Pictures on TV

Connect the camera to a television for playback.

Connecting an HDMI Cable

Always turn the camera off before connecting or disconnecting HDMI cables. When connecting cables, do not use force or attempt to insert the connectors at an angle.

High-Definition Devices

A type D High-Definition Multimedia Interface (HDMI) cable (available separately from third-party suppliers) can be used to connect the camera to high-definition video devices.

1 Connect the HDMI cable.

Turn the camera off and connect the HDMI cable.

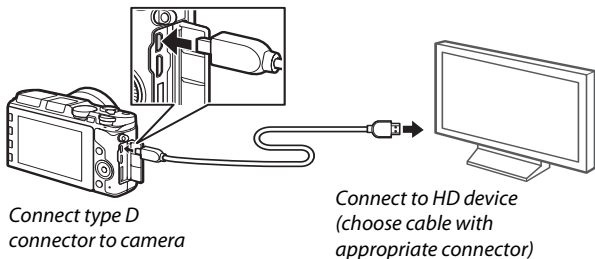

2 Tune the device to the HDMI channel.

3 Turn the camera on.

Turn the camera on; the camera monitor will remain off and the camera shooting mode display will appear on the HD device. Pictures can be played back using camera controls as described elsewhere in this manual; note that the edges of images may not be visible in the display.

Close the Connector Cover

Close the connector cover when the connectors are not in use. Foreign matter in the connectors can interfere with data transfer.

Television Playback

Volume can be adjusted using the controls on the television; adjusting volume on the camera has no effect. Use of an AC adapter and power connector (available separately) is recommended for extended playback.

Electronic VR

Electronic vibration reduction (📖 184) can not be used while an HDMI cable is connected.

■■ HDMI Device Control

To control the camera remotely from a device that supports HDMI-CEC (**H**igh-**D**efinition **M**ultimedia **I**nterface-**C**onsumer **E**lectronics **C**ontrol), select **On** for **HDMI device control** in the camera setup menu. For information on using a remote control, see the television manual.



Printing Photographs

Selected JPEG images can be printed on a PictBridge printer connected directly to the camera.

Connecting the Printer

Connect the camera using the supplied USB cable.

1 Turn the camera off.

2 Connect the USB cable.

Turn the printer on and connect the USB cable. Do not use force or attempt to insert the connectors at an angle.

3 Turn the camera on.

A welcome screen will be displayed in the monitor, followed by a PictBridge playback display. To print pictures one at a time, proceed to page 151. To print multiple selected pictures or all pictures, proceed to page 153.

Selecting Photographs for Printing

Movies and NEF (RAW) photographs (□ 171) can not be selected for printing. If Motion Snapshots are selected, only the photographs will be printed; the movie portion will not be printed. If photographs taken with the Smart Photo Selector are selected, only the best shot will be printed.

Panoramas

Some printers may not print panoramas, while at some settings others may not print entire panoramas. See the printer manual or consult the manufacturer for details.



Printing Pictures One at a Time

1 Display the desired picture.

Press ◀ or ▶ to view additional pictures. Rotate the main command dial right to zoom in on the current frame (☞ 135; rotate the dial left to exit zoom). To view nine pictures at a time, rotate the dial left when a picture is displayed full frame. Use the multi selector to highlight pictures, or rotate the main command dial right to display the highlighted picture full frame.



2 Adjust printer settings.

Press Ⓞ to display the following items, then press ▲ or ▼ to highlight an item and press ▶ to view options (only options supported by the current printer are listed; to use the default option, select **Use printer settings**). After selecting an option, press Ⓞ to return to the printer settings menu.

Option	Description
Page size	Choose a page size.
Number of copies	This option is listed only when pictures are printed one at a time. Press ▲ or ▼ to choose number of copies (maximum 99).
Print border	Choose whether to frame photos in white borders.
Print time stamp	Choose whether to print the times and dates of recordings on photos.
Crop	This option is listed only when pictures are printed one at a time. To exit without cropping, highlight No and press Ⓞ. To crop the current picture, highlight Yes and press ▶. A crop selection dialog will be displayed; rotate the main command dial right to increase the size of the crop, left to decrease. Press ▲, ▼, ◀, or ▶ to position the crop. Note that print quality may drop if small crops are printed at large sizes.



3 Start printing.

Highlight **Start printing** and press  to start printing. To cancel before all copies have been printed, press  again.



Printing Multiple Pictures

1 Display the PictBridge menu.

Press the MENU button in the PictBridge playback display (📖 150).

2 Choose an option.

Highlight one of the following options and press ►.

- **Select images for printing:** Select pictures for printing. Press ◀ or ► or rotate the multi selector to highlight pictures and press ▲ or ▼ to choose the number of prints (up to 99).
- **Print DPOF print order:** Print the current DPOF print order (📖 155). The order can be viewed and modified before printing as described above under “Select images for printing”.
- **Select by date:** Print one copy of each picture taken on selected dates. Press ▲ or ▼ to highlight dates and press ► to select or deselect.
- **Index print:** To create an index print of all JPEG pictures on the memory card, proceed to Step 3. Note that if the memory card contains more than 256 pictures, a confirmation dialog will be displayed and only the first 256 images will be printed. A warning will be displayed if the page size selected in Step 3 is too small.

3 Adjust printer settings.

Adjust printer settings as described in Step 2 on page 151.

4 Start printing.

Highlight **Start printing** and press Ⓞ to start printing. To cancel before all copies have been printed, press Ⓞ again.



Inspecting Pictures

To view pictures taken on the date highlighted in the **Select by date** date list, rotate the main command dial right. Use the multi selector to highlight pictures, or rotate the dial left to return to the date list.

The picture currently highlighted in the **Select images for printing** or **Print DPOF print order** displays or in the **Select by date** thumbnail display can be inspected by pressing the main command dial; the picture will be displayed full screen while the dial is pressed.

Errors

See page 244 for information on what to do if an error occurs during printing.



Creating a DPOF Print Order: Print Set

The **DPOF print order** option is used to create digital “print orders” for PictBridge-compatible printers and devices that support DPOF. Press the MENU button, select **DPOF print order** in the playback menu, and choose from the following options:

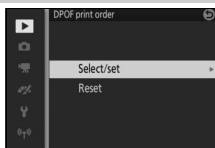

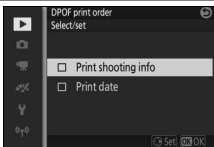
Select/set	Press ◀ or ▶ or rotate the multi selector to highlight pictures (☐ 158). To select the current picture for printing, press ▲. The picture will be marked with a ☐ icon and the number of prints will be set to 1; press ▲ or ▼ to specify the number of prints (up to 99; to deselect the picture, press ▼ when the number of prints is 1). When the selection is complete, press Ⓚ to display printing options. Highlight Print shooting info (print the shutter speed and aperture on all pictures in the print order) or Print date (print the date of recording on all pictures in the print order) and press ▶ to select or deselect, and then press Ⓚ to complete the print order.	 A screenshot of the camera's menu system. The title is 'DPOF print order'. Below the title, it says 'Select/set'. There are two options: 'Print shooting info' and 'Print date', both with checkboxes. The 'Print shooting info' option is currently selected. At the bottom right, there are icons for 'Set' and 'OK'.
Reset	Remove all pictures from the print order.	

DPOF Print Order

DPOF date and shooting info options are not supported when printing via direct USB connection; to print the date of recording on photographs in the current print order, use the PictBridge **Print time stamp** option (☐ 151).

The **DPOF print order** option can not be used if there is not enough space on the memory card to store the print order. For restrictions on the types of images that can be selected for printing, see page 150.

Print orders may not print correctly if images are deleted using a computer or other device after the print order is created.



The Playback Menu

To display the playback menu, press **MENU** and select **Playback**.

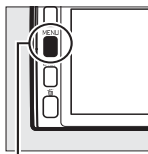

MENU button

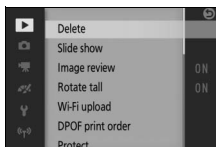

The playback menu contains the following options:

Option	Description	Default	
Delete	Delete multiple images.	—	136
Slide show	View movies and photos in a slide show.	Image type: All images Frame interval: 4 s Movie playback time: Same as frame interval Audio: Movie sound tracks	138
Image review	Choose whether pictures are displayed after shooting.	On	159
Rotate tall	Rotate “tall” (portrait-orientation) pictures for display during playback.	On	159
Wi-Fi upload	Upload selected photos to smart devices via wireless networks.	—	127
DPOF print order	Create digital “print orders”.	—	155
Protect	Protect pictures from accidental deletion.	—	159
Rating	Rate pictures.	—	160

Option	Description	Default	
D-Lighting	Brighten shadows in dark or backlit photos, creating a retouched copy that is saved separately from the unmodified original.	—	160
Resize	Create small copies of selected pictures.	Choose size: 1280×856; 1.1 M	161
Crop	Create cropped copies of selected pictures.	—	162
Edit movie	Create copies of movies from which unwanted footage has been trimmed.	—	163
Combine 4-second movies	Combine multiple 4-second movies into a single movie.	—	165
Combine NMS movies	Make a movie from the movie portions of multiple Motion Snapshots.	—	166

Playback

The camera may be unable to display or retouch images that were created or have been edited with other devices.

Image Quality

Copies created from JPEG photos are the same quality as the original ( 171). NEF (RAW) photos can not be retouched; when retouch options are used with pictures taken at an image quality of **NEF (RAW) + JPEG fine**, the JPEG image will be retouched and saved as a fine-quality JPEG copy.



Selecting Multiple Images

Choosing the options listed below displays an image selection dialog. Press ◀ or ▶ or rotate the multi selector to highlight pictures (only pictures to which the operation applies are available for selection).



- **Delete > Delete selected images** (📖 136)
- **Wi-Fi upload** (📖 127)
- **DPOF print order > Select/set** (📖 155)
- **Protect > Select/set** (📖 159)
- **Rating** (📖 160)
- **D-Lighting** (📖 160)
- **Resize > Select images** (📖 161)
- **Crop** (📖 162)
- **Edit movie** (📖 163)
- **Combine 4-second movies** (📖 165)
- **Combine NMS movies** (📖 166)

Inspecting Pictures

The picture currently highlighted in the thumbnail display can be inspected by pressing the main command dial; the picture will be displayed full screen while the dial is pressed.



Image Review

If **On** is selected, pictures will be displayed immediately after shooting. To view pictures when **Off** is selected, press the  button.







Rotate Tall

Choose whether to rotate “tall” (portrait-orientation) pictures for display during playback. Note that because the camera itself is already in the appropriate orientation during shooting, images are not rotated automatically during image review.

On	“Tall” (portrait-orientation) pictures are automatically rotated for display in the camera monitor. Pictures taken with Off selected for Auto image rotation ( 219) will be displayed in “wide” (landscape) orientation.
Off	“Tall” (portrait-orientation) pictures are displayed in “wide” (landscape) orientation.

Protect

Protect selected images from accidental deletion. Note that this option does NOT protect files from deletion when the memory card is formatted ( 211).

Select/set	Press  or  or rotate the multi selector to highlight pictures ( 158) and press  or  to select or deselect. Press  to exit when the operation is complete.
Reset	Remove protection from all pictures.



Rating

Press ◀ or ▶ or rotate the multi selector to highlight pictures (📖 158) and press ▲ or ▼ to choose a rating (📖 137). Press Ⓞ to exit when the operation is complete.

D-Lighting

Applied to selected images, D-Lighting creates copies that have been processed to brighten shadows.

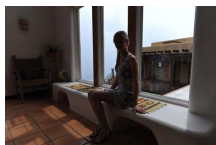

Before



After

Press ◀ or ▶ or rotate the multi selector to highlight an image (📖 158) and press Ⓞ to display the options shown at right. Press ▲ or ▼ to choose the amount of correction performed (the effect can be previewed in the display; press and hold the main command dial to zoom in) and press Ⓞ to create a retouched copy.

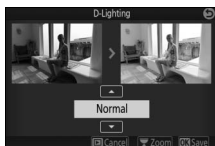

D-Lighting

Noise (randomly-spaced bright pixels, fog, or lines) may appear in copies created with **D-Lighting**. Uneven shading may be visible with some subjects.

Image Size

Copies are the same size as the original.

Resize

Create small copies of selected photographs. Select **Choose size** and choose a size from **1280×856; 1.1 M** (1280 × 856 pixels), **960×640; 0.6 M** (960 × 640 pixels), and **640×424; 0.3 M** (640 × 424 pixels), and then choose **Select images**. Press ◀ or ▶

or rotate the multi selector to highlight pictures (📖 158) and press ▲ or ▼ to select or deselect. When the selection is complete, press Ⓚ to display a confirmation dialog and select **Yes** to save the resized copies.



Resized Copies

Playback zoom may not be available with resized copies.



Crop

Create a cropped copy of selected photographs. Press ◀ or ▶ or rotate the multi selector to highlight a picture (158) and press OK to display the image with the default crop shown in yellow. Use the controls below to choose a crop and save the copy.



To	Use	Description
Choose size		Rotate the main command dial to choose the crop size.
Choose aspect ratio		Rotate the multi selector or sub-command dial to choose between aspect ratios of 3 : 2, 4 : 3, 1 : 1, and 16 : 9.
Position crop		Press ▲, ▼, ◀, or ▶ to position the crop.
Create copy		Save the current crop as a separate file.

Cropped Copies

Playback zoom may not be available with cropped copies. The size of the copy varies with crop size and aspect ratio and appears at upper left in the crop display.

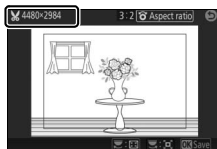

Edit Movie

Trim footage from movies to create edited copies.

1 Choose an edit option.

Highlight one of the following options and press ►:

- **Choose start point:** Remove all frames before a chosen starting frame.

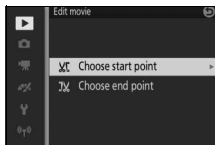

- **Choose end point:** Remove all frames after a chosen closing frame.

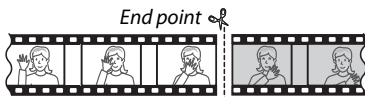

2 Select a movie.

Press ◀ or ▶ or rotate the multi selector to highlight a movie (📖 158) and press OK to select.



3 Pause the movie on opening or closing frame.

Play the movie back, pressing **OK** to begin and resume playback and **▼** to pause (see 65; the first frame is indicated by a **▶** icon in the display, the last frame by **◀**). While playback is paused, press **◀** or **▶** to rewind or advance one frame at a time. Pause playback when you reach the frame that will become the new opening or closing frame.



4 Delete the unwanted frames.

Press **▲** to delete all frames before (**Choose start point**) or after (**Choose end point**) the current frame.



5 Save the copy.

Highlight **Yes** and press **OK** to save the edited copy. If necessary, the copy can be trimmed as described above to remove additional footage.

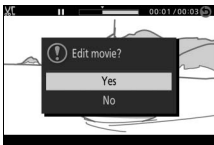

Trimming Movies

Movies must be at least two seconds long. If a copy can not be created at the current playback position, the current position will be displayed in red in Step 4 and no copy will be created. The copy will not be saved if there is insufficient space available on the memory card.

To prevent the camera from turning off unexpectedly, use a fully-charged battery when editing movies.

Combine 4-Second Movies

Combine up to eight 4-second movies into a single movie (4-second movies are recorded using the **4-second movie** option in advanced movie mode; for more information, see page 62).

1 Select movies.

Select 4-second movies as described on page 158. Press ▲ or ▼ to view or hide the order in which the clips will appear in the final movie. To preview a clip, highlight it and press the DISP button.



2 Combine the selected movies.

Press **OK**. A confirmation dialog will be displayed; select **Yes** to join the selected clips and their audio tracks into a new movie, which is stored separately from its component clips.



Combine NMS Movies

Combine the movie segments of up to eight NMS-format Motion Snapshots (📖 176) into a single movie.

1 Select Motion Snapshots.

Select Motion Snapshots as described on page 158. Press ▲ or ▼ to view or hide the order in which the clips will appear in the final movie. To preview the movie portion of the highlighted Motion Snapshot, press the DISP button.

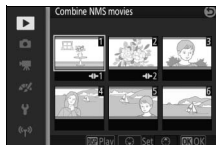

2 Combine the selected Motion Snapshots.

Press Ⓞ. A confirmation dialog will be displayed; select **Yes** to join the movie portions of the selected Motion Snapshots into a new movie, which is stored separately from its component clips. Any audio included in Motion Snapshots recorded with **Audio** (📖 90) set to **Ambient** will be included in the new movie.





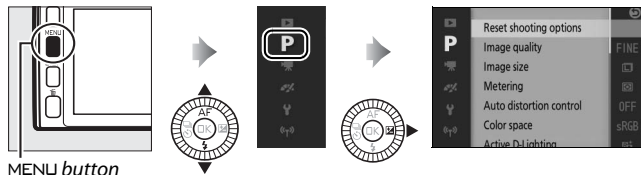

The Shooting Menu

To display the shooting menu, press **MENU** and select **Shooting**.





The shooting menu contains the following options:

Option	Description	Default	
Reset shooting options	Reset shooting options to default values.	—	235
Creative	Choose a creative mode.	Creative Palette	50
Best moment capture	Choose from Active Selection , Slow view , and Smart Photo Selector .	Active Selection	76
Exposure mode	Choose how the camera sets shutter speed and aperture in Motion Snapshot mode and when Active Selection or Slow view is chosen in best moment capture mode.	Scene auto selector	170
Image quality	Choose a file format and compression ratio.	JPEG fine	171
Image size	Choose a size for new photos.	5232 × 3488; 18.2 M (standard photos)/ Normal panorama (panoramas)	172
Active Selection	Choose the frames Active Selection (76) records to temporary storage, the length of time over which the frames are captured, and the default number of frames saved.	On release, record: Preceding and following Capture 40 frames over: 2/3 s Frames saved (default): 1	174

Option	Description	Default	
Number of shots saved	Choose the number of shots selected by the Smart Photo Selector ( 82).	5	175
Movie before/after	Choose when the movie portion of Motion Snapshots is recorded ( 87).	1.0 s : 0.6 s	175
File format	Choose a file format for new Motion Snapshots ( 87).	NMS files	176
Audio	Choose the audio recorded with Motion Snapshots ( 87).	Background music	90
Select color	Choose the hue that appears in color in pictures taken with Selective color selected in creative mode.	—	57
Soft	Choose amount of softening applied to pictures taken with Soft selected in creative mode. You can also choose how softening applies to pictures with portrait subjects.	Filter strength: Normal Portrait: On	176
Hue	Choose base hue for pictures taken with Cross process selected in creative mode.	Blue	58
Toy camera effect	Adjust saturation and vignetting for pictures taken with Toy camera effect selected in creative mode.	Saturation: Normal Vignetting: Normal	177
Metering	Choose how the camera meters exposure.	Matrix	177



Option	Description	Default	
Autodistortion control	Choose whether the camera corrects barrel and pin-cushion distortion.	Off	178
Color space	Choose a color space for new pictures.	sRGB	178
Active D-Lighting	Avoid loss of detail in highlights and shadows.	On	179
Long exposure NR	Reduce noise in long time-exposures.	Off	180
Interval timer shooting	Take photos at a pre-selected interval.	01' 00", 001	181
Optical VR	Adjust settings for 1 NIKKOR lenses with vibration reduction.	Active/On *	183
Electronic VR	Choose whether to use electronic vibration reduction in Motion Snapshot mode ( 87).	Off	184
Focus mode	Choose how the camera focuses.	See page 99	99
AF-area mode	Choose how the focus area is selected.	Auto-area	185
Face-priority	Turn face priority on or off.	On	—
Built-in AF assist	Control the built-in AF-assist illuminator.	On	186
Flash control	Choose a flash mode for the built-in and optional flash units.	TTL (Manual: Full)	187
Flash compensation	Control flash output.	0.0	188

*Varies with lens ( 183).



Exposure Mode

The options in the exposure mode menu offer varying degrees of control over shutter speed and aperture in Motion Snapshot and advanced movie modes (☞ 61, 87) and when **Active Selection** or **Slow view** is chosen in best moment capture mode (☞ 76).

 Scene auto selector	An automatic, “point-and-shoot” mode in which the camera not only chooses shutter speed and aperture but adjusts other settings to suit the subject (automatic scene selection; ☞ 44).
P Programmed auto	The camera sets shutter speed and aperture for optimal exposure (☞ 70). Recommended for snapshots and in other situations in which there is little time to adjust camera settings.
S Shutter-priority auto	You choose the shutter speed; the camera selects an aperture for best results (☞ 71). Use to freeze or blur motion.
A Aperture-priority auto	You choose the aperture; the camera selects a shutter speed for best results (☞ 72). Use to blur the background or bring both foreground and background into focus.
M Manual	You control both shutter speed and aperture (☞ 73). Set shutter speed to “Bulb” or “Time” for long time-exposures.



Image Quality

Choose a file format and compression ratio for photographs.

Option	File type	Description
NEF (RAW)	NEF	Compressed 12-bit raw data from the image sensor are saved directly to the memory card. White balance, contrast, and other settings can be adjusted on a computer after shooting.
JPEG fine	JPEG	Record JPEG images at a compression ratio of roughly 1 : 4 (fine quality).
JPEG normal		Record JPEG images at a compression ratio of roughly 1 : 8 (normal quality).
NEF (RAW) + JPEG fine	NEF/ JPEG	Two images are recorded: one NEF (RAW) image and one fine-quality JPEG image.





Image Size

Choose the size of photographs.

■ Standard Photographs



The following options are available in still image and Smart Photo Selector modes and when an option other than **Easy panorama** is selected in creative mode.

Option	Size (pixels)	Approximate print size at 300 dpi (cm/in.)*
 5232×3488; 18.2 M	5232 × 3488	44.3 × 29.5/ 17.4 × 11.6
 3920×2616; 10.3 M	3920 × 2616	33.2 × 22.1/ 13.1 × 8.7
 2608×1744; 4.5 M	2608 × 1744	22.1 × 14.8/ 8.7 × 5.8

* Print size in inches equals image size in pixels divided by printer resolution in dots per inch (dpi; 1 inch=approximately 2.54 cm).

■ Panoramas

The following options are available when **Easy panorama** is selected in creative mode.

Option	Size (pixels) ¹	Approximate print size at 300 dpi (cm/in.) ²
 Normal panorama	Camera panned horizontally: 4800 × 920	40.6 × 7.8/16.0 × 3.1
	Camera panned vertically: 1536 × 4800	13.0 × 40.6/5.1 × 16.0
 Wide panorama	Camera panned horizontally: 9600 × 920	81.3 × 7.8/32.0 × 3.1
	Camera panned vertically: 1536 × 9600	13.0 × 81.3/5.1 × 32.0

1 Figures for horizontal and vertical panorama are reversed if camera is rotated 90 degrees.

2 Print size in inches equals image size in pixels divided by printer resolution in dots per inch (dpi; 1 inch=approximately 2.54 cm).



NEF (RAW)/NEF (RAW) + JPEG

The option selected for image size does not affect the size of NEF (RAW) images. NEF (RAW) images can be viewed on the camera or using software such as Capture NX 2 (available separately;  223) or ViewNX 2 (supplied).

When photographs taken at NEF (RAW) + JPEG are viewed on the camera, only the JPEG image will be displayed. When photographs taken at these settings are deleted, both NEF and JPEG images will be deleted.

File Names

Photos and movies are stored as image files with names of the form “xxx_nnnn.yyy,” where:

- xxx is either NMS (Motion Snapshots recorded with **NMS files** selected for **File format**;  176) or DSC (photos, MOV-format Motion Snapshots, and movies),
- nnnn a four-digit number between 0001 and 9999 assigned automatically in ascending order by the camera, and
- yyy one of the following three-letter extensions: “NEF” for NEF (RAW) images, “JPG” for JPEG images, or “MOV” for movies.



The NEF and JPEG files recorded at settings of NEF (RAW)+JPEG have the same file names but different extensions. Copies created with the retouch options in the playback menu have file names beginning with “CSC” (e.g., “CSC_0001.JPG”). Images recorded with **Adobe RGB** selected for **Color space** ( 178) have names that begin with an underscore (e.g., “_DSC0001.JPG”).

Image Quality and Size

Together, image quality and size determine how much space each photograph occupies on the memory card. Larger, higher quality images can be printed at larger sizes but also require more memory, meaning that fewer such images can be stored on the memory card ( 236).



Active Selection

Choose the frames Active Selection (📖 76) records to temporary storage, the length of time over which the frames are captured, and the default number of frames saved.

■ On Release, Record

Choose the frames copied from the buffer to temporary storage when the shutter-release button is pressed all the way down.

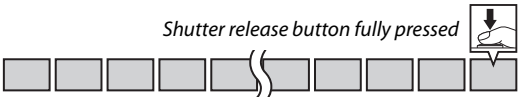
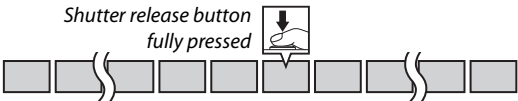
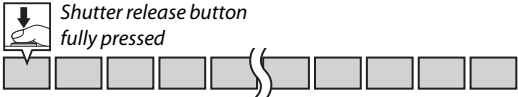
Preceding frames	<p>The camera captures the 40 preceding frames.</p> <p style="text-align: center;"><i>Shutter release button fully pressed</i></p>  <p>The diagram shows a sequence of 40 frames represented by grey squares. A bracket groups the first 40 frames. An icon of a hand pressing a shutter release button with a downward arrow is positioned at the end of the sequence, with a callout line pointing to the 40th frame.</p>
Preceding and following	<p>The camera captures 40 frames, starting before and ending after the moment the shutter-release button is pressed all the way down.</p> <p style="text-align: center;"><i>Shutter release button fully pressed</i></p>  <p>The diagram shows a sequence of 40 frames represented by grey squares. A bracket groups the first 40 frames, which includes frames before and after the shutter release button is pressed. An icon of a hand pressing a shutter release button with a downward arrow is positioned in the middle of the sequence, with a callout line pointing to the 40th frame.</p>
Following frames	<p>The camera captures the 40 following frames.</p> <p style="text-align: center;"><i>Shutter release button fully pressed</i></p>  <p>The diagram shows a sequence of 40 frames represented by grey squares. A bracket groups the last 40 frames. An icon of a hand pressing a shutter release button with a downward arrow is positioned at the beginning of the sequence, with a callout line pointing to the 1st frame.</p>

■ Capture 40 Frames Over

Choose whether the frames are captured over $\frac{2}{3}$ s (a frame rate of 60 fps), $\frac{1}{3}$ s (30 fps), or 2 s (20 fps).

■ Frames Saved (Default)

Choose the number of frames selected by default in the confirmation dialog displayed when shooting is complete: the frame recorded to the buffer when the shutter-release button was pressed (1) or all the frames in temporary storage (All).



Number of Shots Saved

Choose the number of shots selected by the Smart Photo Selector. If **5** is selected, the camera will save the best shot and 4 best shot candidates. If **1** is selected, the camera will save only the best shot.

Movie Before/After

Choose whether the movie portions of Motion Snapshots end when the shutter-release button is pressed all the way or about 0.6 s after (📖 87). If **1.6 s : 0 s** is selected, the photograph used for the Motion Snapshot will feature the last frame of the movie.

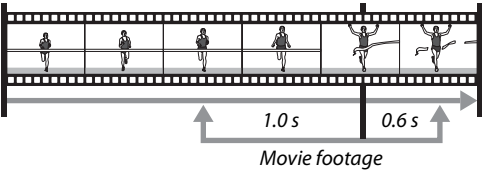
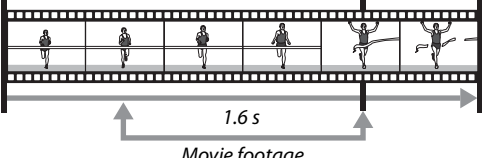
1.0 s : 0.6 s	<p>Movie footage starts about a second before the shutter-release button is pressed all the way down and ends about 0.6 s after.</p> <p><i>Shutter-release button pressed halfway</i> <i>Shutter-release button pressed all the way down</i></p>  <p>1.0 s 0.6 s</p> <p><i>Movie footage</i></p>
1.6 s : 0 s	<p>The camera records about 1.6 s of movie footage, ending when the shutter-release button is pressed all the way down.</p> <p><i>Shutter-release button pressed halfway</i> <i>Shutter-release button pressed all the way down</i></p>  <p>1.6 s</p> <p><i>Movie footage</i></p>



File Format

Choose the file format for Motion Snapshots (☞ 87).

NMS files	Motion Snapshots are recorded as a 4 s MOV file and a JPEG image. Motion Snapshots can only be viewed on the camera or using ViewNX 2 (☞ 142).
MOV file	Motion Snapshots are recorded as a 10 s MOV file that can be viewed in a variety of computer applications. The Motion Snapshot is not displayed automatically when shooting ends (☞ 88); for information on viewing Motion Snapshot movies, see page 65.

Soft

Choose amount of softening applied to pictures taken with **Soft** selected in creative mode. You can also choose how softening applies to portrait subjects.

■ Filter strength

Choose from **High**, **Normal**, and **Low**.

■ Portrait

If **On** is selected and the camera detects portrait subjects (up to three), softening will be adjusted to make them stand out. If **Off** is selected, softening will be applied equally to the portrait subject and the background.



Toy Camera Effect

Adjust saturation and vignetting for pictures taken with **Toy camera effect** selected in creative mode.

■ ■ Saturation





Choose from **High**, **Normal**, and **Low**.

■ ■ Vignetting

Choose the amount of vignetting from **High**, **Normal**, and **Low**.

Metering

Choose how the camera sets exposure.

 Matrix	The camera meters a wide area of the frame and adjusts for contrast (tone distribution), color, composition, and subject distance, producing natural results in most situations.
 Center-weighted	The camera meters the entire frame but assigns the greatest weight to the center area. This is the classic meter for portraits and is recommended if you are using filters with an exposure factor (filter factor) over 1x.
 Spot	The camera meters the current focus area; use to meter off-center subjects (if Auto-area is selected for AF-area mode as described on page 185, the camera will meter the center focus area, while during face priority the camera will meter the focus area closest to the center of the selected face;  45). Spot metering ensures that the subject will be correctly exposed, even when framed against a background that is much brighter or darker.



Auto Distortion Control

Select **On** to reduce barrel distortion in photos taken with wide-angle lenses and to reduce pin-cushion distortion in photos taken with long lenses (note that the edges of photographs may be cropped out, and that there may be an increase in the time needed to process images before they are saved). This option is available only with 1 NIKKOR lenses and not with other NIKKOR lenses attached using the FT1 mount adapter. Results are not guaranteed with third-party lenses.

Color Space

The color space determines the gamut of colors available for color reproduction. Choose **sRGB** for general-purpose printing and display; **Adobe RGB**, with its broader gamut of colors, is more suited to shots destined for professional publication and commercial printing.

Adobe RGB

For accurate color reproduction, Adobe RGB images require applications, displays, and printers that support color management.

Color Space

ViewNX 2 (supplied) and Capture NX 2 (available separately) automatically select the correct color space when opening photographs created with this camera. Results can not be guaranteed with third-party software.



Active D-Lighting

Active D-Lighting preserves details in highlights and shadows for natural contrast. Use with high contrast scenes such as a brightly lit outdoor view framed in a door or window or a subject in the shade on a sunny day. It is most effective when used with **Matrix** metering (☞ 177).



Active D-Lighting: **Off**



Active D-Lighting: **☑ On**

☑ Active D-Lighting

Noise (randomly-spaced bright pixels, fog, or lines) may appear in photographs taken with Active D-Lighting. Uneven shading may be visible with some subjects.

☑ "Active D-Lighting" Versus "D-Lighting"

The **Active D-Lighting** option in the shooting menu adjusts exposure before shooting to optimize the dynamic range, while the **D-Lighting** option in the playback menu (☞ 160) brightens shadows in images after shooting.



Long Exposure NR

Photographs taken at slow shutter speeds are automatically processed to reduce “noise” (bright spots, randomly-spaced bright pixels, or fog), slightly increasing recording times. Selecting **On** increases the amount of noise reduction performed at shutter speeds slower than 1 s and increases the time required to record images by roughly 1.5 to 2 times. During processing, a warning will be displayed and pictures can not be taken (if the camera is turned off before processing is complete, the picture will be saved but noise reduction will not be performed). In continuous release mode, frame rates will slow and while photographs are being processed, the capacity of the memory buffer will drop.



Interval Timer Shooting

Take photographs automatically at preset intervals.

✔ Before Shooting

Before proceeding, check that the clock is set correctly (📖 31, 218) and then take a test shot at current settings and view the results in the monitor.

Use of a tripod is recommended. To ensure that shooting is not interrupted, be sure the battery is fully charged or use an optional AC adapter and power connector.

1 Choose the interval.

Highlight **Interval** and press ► to view the interval. Press ◀ or ▶ to highlight minutes or seconds and press ▲ or ▼ to choose an interval longer than the slowest anticipated shutter speed. Press Ⓞ to return to the interval timer shooting menu when settings are complete.

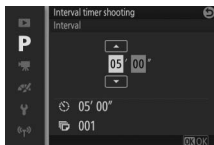

2 Choose the number of intervals.

Highlight **Number of shots** and press ►, then use the multi selector to choose the number of intervals. Press Ⓞ to return to the interval timer shooting menu when settings are complete.

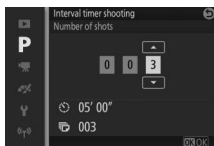

3 Start shooting.

Highlight **Start** and press \odot (OK). Shooting will start after about 3 s, and continue at the selected interval until all the shots have been taken (one shot is taken at each interval). Note that the pause following the recording of each shot varies with shutter speed and the time needed to record the image, with the result that photographs may not be recorded at the selected interval.

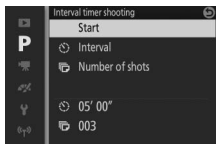

Interval Timer Photography

A warning will be displayed if the camera is unable to start interval timer photography at current settings (for example, when "Bulb" is selected for shutter speed). While interval timer photography is in progress, settings can not be adjusted and the camera will not turn off automatically (□ 29).

Interrupting Interval Timer Photography

Interval timer shooting ends and interval timer settings are reset when the camera is turned off, the battery is exhausted, the memory card is full, the mode dial is rotated to a new setting, or the MENU or \blacktriangleright button is pressed.



Optical VR

This option is available with 1 NIKKOR lenses that support vibration reduction (VR). The options available vary with the type of lens: **Normal/Active/Off** for lenses that support active vibration reduction and **On/Off** for other VR lenses. Choose **Active, Normal**, or **On** to reduce the effects of vibration; choose **Active** when shooting from a moving vehicle or while walking or for other forms of strong camera shake, **Normal** for the relatively mild camera shake that occurs while standing still.

Vibration Reduction

When the camera is panned, vibration reduction applies only to motion that is not part of the pan (if the camera is panned horizontally, for example, vibration reduction will be applied only to vertical shake), making it much easier to pan the camera smoothly in a wide arc. The composition may appear to change after the shutter is released, but this does not indicate a malfunction.



Electronic VR

Select **On** to enable electronic vibration reduction in Motion Snapshot mode (📖 87), when filming movies in auto, creative, P, S, A, and M modes, and when **HD movie** is selected in advanced movie mode (📖 62, but note that electronic VR is not available when **1080/60p** or **720/60p** is selected for **Frame size/frame rate**). This feature is available even if the attached 1 NIKKOR lens does not support vibration reduction. Note that there will be a slight delay before recording begins. The area recorded is shown by guides in the display; the appearance of the guides depends on the option selected for **Electronic VR**.

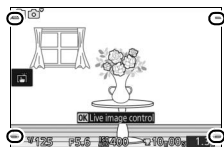

Electronic vibration reduction off

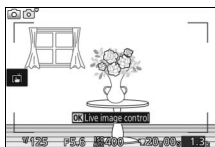







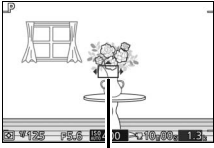

Electronic vibration reduction on

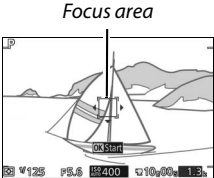

AF-Area Mode

Choose how the focus area for autofocus is selected.

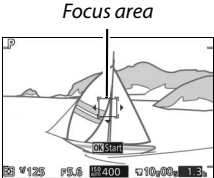
 Auto-area	The camera automatically detects the subject and selects the focus area.	 <p><i>Focus area</i></p>
 Single-point	Press  to view the focus area selection display, then use the multi selector to position the focus area over your subject and press  ; the camera focuses on the subject in the selected focus area only. Use with stationary subjects.	 <p><i>Focus area</i></p>
 Subject tracking	Press  to view the focus area selection display, then use the multi selector to position the focus area over your subject and press  . The focus area will track the subject as it moves through the frame. The camera will focus on the selected subject when the shutter-release button is pressed halfway. To end focus tracking when shooting is complete, press  .	

Subject Tracking

The camera may be unable to track subjects if they move quickly, leave the frame or are obscured by other objects, change visibly in size, color, or brightness, or are too small, too large, too bright, too dark, or similar in color or brightness to the background.



Built-in AF Assist

When **On** is selected, the built-in AF-assist illuminator will light to illuminate poorly-lit subjects if:

- **AF-S** is selected for focus mode (📖 99) or single AF is selected in **AF-A**, and
- **Auto-area** or **Single-point** is selected for **AF-area mode** (📖 185).

AF-assist illuminator



The AF-assist illuminator will not light to assist the focus operation in advanced movie mode, during movie recording, or when **Off** is selected. If the AF-assist illuminator does not light, autofocus may not produce the desired results when lighting is poor.



The AF-Assist Illuminator

Larger lenses may prevent the illuminator lighting all or part of the subject. Remove lens hoods when using the illuminator.



Flash Control

Choose a flash control mode for the built-in and optional flash units.

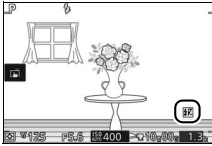
TTL ↕ TTL	Flash output is adjusted automatically in response to shooting conditions (i-TTL flash control).
M ↕ Manual	<p>Choose a flash level between Full and 1/32 (1/32 of full power). At full power, the built-in flash has a guide number of about 5/16 (m/ft, ISO 100, 20 °C/68 °F; at ISO 160, the guide number is about 6.3/20.7).</p> <p>A  icon flashes in the display during flash photography when this option is selected.</p>  



Flash Compensation

Flash compensation alters flash output from the level suggested by the camera, changing the brightness of the main subject relative to the background. Choose from values between -3 EV (darker) and $+1$ EV (brighter) in increments of $\frac{1}{3}$ EV; in general, positive values make the subject brighter while negative values make it darker.

A  icon is displayed when flash compensation is in effect. Normal flash output can be restored by setting flash compensation to ± 0 . Flash compensation is not reset when the camera is turned off.

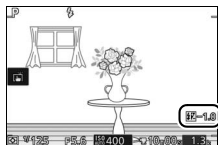
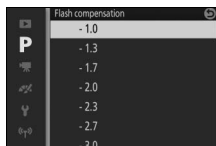

The Movie Menu

To display the movie menu, press **MENU** and select **Movies**.

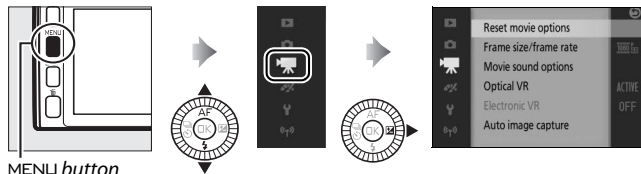

The movie menu contains the following options:

Option	Description	Default	
Reset movie options	Reset movie menu options to their default values.	—	—
Advanced movie	Choose a movie type for advanced movie mode.	HD movie	62
Exposure mode	Choose how the camera sets exposure in advanced movie mode.	Scene auto selector	170
Slow motion	Choose a frame rate for slow-motion movies recorded in advanced movie mode (62).	400 fps	191
Frame size/frame rate	Choose a frame size and rate for movies recorded in auto, creative, P, S, A, and M modes and when HD movie is selected in advanced movie mode (62).	1080/60p	192
Metering	Choose how the camera meters exposure.	Matrix	177
Movie sound options	Choose sound recording options.	Microphone: Auto sensitivity (A) Wind noise reduction: On	193



Option	Description	Default	
Optical VR	Adjust settings for 1 NIKKOR lenses with vibration reduction.	Active/On ¹	183
Electronic VR	Choose whether to use electronic vibration control when recording movies.	Off	184
Focus mode	Choose how the camera focuses.	See page 99	99
AF-area mode	Choose how the focus area is selected.	Auto-area ²	185
Face-priority	Turn face priority on or off.	On ³	—
Auto image capture	Choose whether the camera takes photos automatically during movie recording and select the number of pictures taken per minute.	Auto photography: Off Max. shots per minute: 4	194

1 Varies with lens ( 183).

2 The camera focuses on the subject in the center of the frame when  **Slow motion** is selected in advanced movie mode.

3 Face detection is not available when  **Slow motion** is selected in advanced movie mode.



Slow Motion

Choose a frame rate for slow-motion movies (📄 62). The faster the frame rate, the smaller the frame size.

Option	Frame size (pixels)	Bit rate ¹	Maximum length (shooting) ¹	Maximum length (playback) ^{1,2}
120 fps	1280 × 720	24 Mbps	3 seconds	12 seconds
400 fps	768 × 288	2 Mbps		40 seconds
1200 fps	416 × 144	1 Mbps		120 seconds

1 All figures are approximate.

2 Slow-motion movies will play back over a period of about 4 (120 fps), 13 (400 fps), or 40 (1200 fps) times the recording time.

See Also

For information on the total length of movies that can be stored on the memory card, see page 238.



Frame Size/Frame Rate

Choose a frame size and frame rate for movies recorded in auto, creative, P, S, A, and M modes and when **HD movie** is selected in advanced movie mode (📖 62).





Option	Frame size (pixels)	Recording rate	Bit rate (approx.)	Maximum length
 1080/60p	1920 × 1080	59.94 fps	42 Mbps	10 minutes
 1080/30p		29.97 fps	24 Mbps	20 minutes
 720/60p	1280 × 720	59.94 fps	16 Mbps	29 minutes
 720/30p		29.97 fps	12 Mbps	

Photo Frame Size

Photographs recorded by pressing the shutter-release button all the way down during movie recording have an aspect ratio of 3 : 2. The frame size varies with the option selected for **Frame size/frame rate**:

- **1080/60p and 1080/30p**: 5232 × 3488 pixels
- **720/60p and 720/30p**: 1472 × 984 pixels

See Also

For information on the total length of movies that can be stored on the memory card, see page 238.



Movie Sound Options

Adjust movie sound recording settings for the built-in microphone and optional external microphones (📖 222).

■ Microphone

Select **Microphone off** to disable sound recording. Selecting any other option enables recording and sets the microphone to the selected sensitivity.

The 🚫 Icon

Movies recorded with the microphone off are indicated by a 🚫 icon in full-frame and movie playback.

■ Wind Noise Reduction

Select **On** to enable the low-cut filter, reducing noise produced by wind blowing over the microphone (note that other sounds may also be affected).

Wind Noise Reduction

To disable wind noise reduction when using an optional ME-1 stereo microphone, slide the microphone low-cut filter switch to FLAT and select **Off** for **Wind noise reduction**.



Auto Image Capture

Choose whether the camera takes photos automatically while movies are being recorded in auto, creative, **P**, **S**, **A**, or **M** mode or with **HD movie** selected in advanced movie mode. Photos will be taken when a suitably-framed portrait subject is in focus and the composition is stable. The maximum number of photos that can be taken during a single clip is 20, including photos taken manually (📖 64).

Auto photography	The camera will take photos automatically during movie recording if On is selected.
Max. shots per minute	Choose the maximum number of shots per minute (one or four).



The Image Processing Menu

To display the image processing menu, press **MENU** and select **Image processing**.

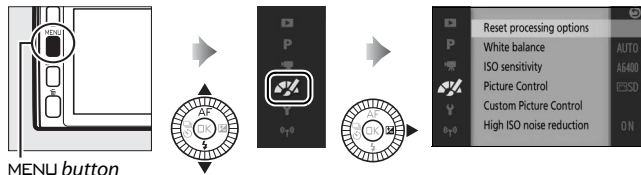







The image processing menu contains the following options:

Option	Description	Default	
Reset processing options	Reset image processing options to their default values.	—	—
White balance	Adjust settings for different types of lighting.	Auto	196
ISO sensitivity	Control the camera's sensitivity to light.	Auto (160–6400)	201
Picture Control	Choose how the camera processes pictures.	Standard	202
Custom Picture Control	Create custom Picture Controls.	—	206
High ISO noise reduction	Reduce noise at high ISO sensitivities.	On	208



White Balance

White balance ensures that colors are unaffected by the color of the light source. Auto white balance is recommended for most light sources, but other values can be selected if necessary according to the type of source.

AUTO Auto	Automatic white balance adjustment. Recommended in most situations.
 Incandescent	Use under incandescent lighting.
 Fluorescent	Use with cool-white fluorescent lighting.
 Direct sunlight	Use with subjects lit by direct sunlight.
 Flash	Use with built-in or optional flash units.
 Cloudy	Use in daylight under overcast skies.
 Shade	Use in daylight with subjects in the shade.
PRE Preset manual	Measure white balance (📖 198).



Fine-Tuning White Balance

Options other than **Preset manual** can be fine-tuned as follows:

1 Display fine-tuning options.

Highlight an option other than **Preset manual** and press **▶** to display the fine-tuning options shown at right.

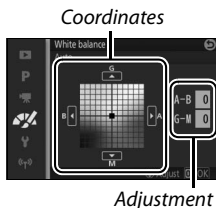

2 Fine-tune white balance.

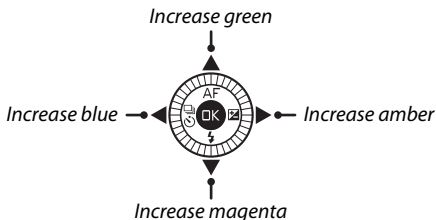

Use the multi selector to fine-tune white balance.



White Balance Fine Tuning

The colors on the fine-tuning axes are relative, not absolute. For example, moving the cursor to **B** (blue) when a “warm” setting such as  (incandescent) is selected will make photographs slightly “colder” but will not actually make them blue.

3 Save changes and exit.

Press **Ⓚ**. An asterisk will appear next to the white balance icon ( 5) in the detailed display ( 6) to show that white balance has been altered from default values.



Preset Manual

Preset manual is used to record and recall custom white balance settings for shooting under mixed lighting or to compensate for light sources with a strong color cast.

1 Light a reference object.

Place a neutral gray or white object under the lighting that will be used in the final photograph. A standard gray panel can be used for increased precision.

2 Select Preset manual.

Highlight **Preset manual** in the white balance menu and press **▶**. The dialog shown at right will be displayed; highlight **Yes** and press **OK** to overwrite the existing value for preset manual white balance.



The message shown at right will be displayed.

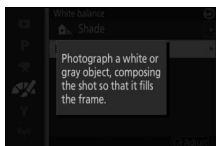

3 Measure white balance.

When the camera is ready to measure white balance, a flashing PRE will be displayed. Before the indicator stops flashing, frame the reference object so that it fills the display and press the shutter-release button all the way down. No photograph will be recorded; white balance can be measured accurately even when the camera is not in focus.

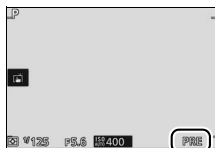

4 Check the results.

If the camera was able to measure a value for white balance, the message shown at right will be displayed. To return to shooting mode immediately, press the shutter-release button half-way.

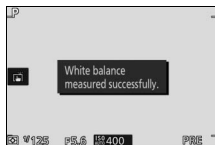

If lighting is too dark or too bright, the camera may be unable to measure white balance. The message at right will be displayed. Return to Step 3 and measure white balance again.

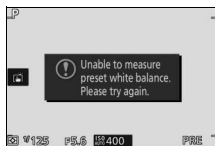

Auto Power Off

White balance measurement will end without a new value being acquired if no operations are performed for the time selected for **Auto power off** in the setup menu (☐ 213; the default is 1 minute).

Preset White Balance

The camera can store only one value for preset white balance at a time; the existing value will be replaced when a new value is measured. Note that exposure is automatically increased by 1 EV when measuring white balance; in mode M, adjust exposure so that the exposure indicator shows ± 0 (☐ 73).

Color Temperature

The perceived color of a light source varies with the viewer and other conditions. Color temperature is an objective measure of the color of a light source, defined with reference to the temperature to which an object would have to be heated to radiate light in the same wavelengths. While light sources with a color temperature in the neighborhood of 5000–5500 K appear white, light sources with a lower color temperature, such as incandescent light bulbs, appear slightly yellow or red. Light sources with a higher color temperature appear tinged with blue. The camera white balance options are adapted to the following color temperatures (all figures are approximate):

- | | |
|---|--|
| • Sodium-vapor lamps: 2700 K | •  (direct sunlight): 5200 K |
| •  (incandescent)/ | •  (flash): 5400 K |
| Warm-white fluorescent: 3000 K | •  (cloudy): 6000 K |
| • White fluorescent: 3700 K | • Daylight fluorescent: 6500 K |
| •  (cool-white fluorescent): 4200 K | • Mercury-vapor lamps: 7200 K |
| • Day white fluorescent: 5000 K | •  (shade): 8000 K |



ISO Sensitivity

The camera's sensitivity to light can be adjusted according to the amount of light available. The higher the ISO sensitivity, the less light needed to make an exposure, allowing faster shutter speeds or smaller apertures.

A6400 Auto (160–6400) A3200 Auto (160–3200) A800 Auto (160–800)	The camera adjusts ISO sensitivity in response to lighting conditions. ISO sensitivity is adjusted in the range given in brackets; choose larger ranges for increased sensitivity when lighting is poor, smaller ranges to reduce noise (randomly-spaced bright pixels, fog, or lines).
160, 200, 400, 800, 1600, 3200, 6400, 6400 (NR), 12800, 12800 (NR)	ISO sensitivity is fixed at the selected value. If 6400 (NR) or 12800 (NR) is selected, the camera will take four shots each time the shutter-release button is pressed all the way down and combine them to create a single image processed to reduce the noise that occurs at high sensitivities.

"Auto" ISO Sensitivity Options

When auto ISO sensitivity control is in effect, the display shows an **ISO AUTO** icon and the current ISO sensitivity.

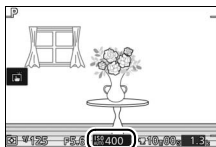







6400 (NR)/12800 (NR)

The edges of the image will be cropped out and built-in and optional flash units and Active D-Lighting can not be used. The desired results may not be achieved if the camera or subject moves during shooting. If **NEF (RAW)** or **NEF (RAW) + JPEG fine** is selected for image quality, the picture will be recorded as a fine-quality JPEG image. Only one shot will be taken if the shutter speed is slower than $\frac{1}{30}$ s.



Picture Control

Choose how the camera processes photographs.

 SD Standard	Standard processing for balanced results. Recommended in most situations.
 NL Neutral	Minimal processing for natural results. Choose for photographs that will later be extensively processed or retouched.
 VI Vivid	Pictures are enhanced for a vivid, photoprint effect. Choose for photographs that emphasize primary colors.
 MC Monochrome	Take monochrome photographs.
 PT Portrait	Process portraits for natural texture and a rounded feel.
 LS Landscape	Take vibrant photographs of landscapes and cityscapes.

Modifying Picture Controls

Existing preset and custom Picture Controls (📖 206) can be modified to suit the scene or your creative intent.

1 Display options.

Highlight an item in the Picture Control menu and press ► to display Picture Control settings (📖 204; the settings available with custom Picture Controls are the same as the preset controls on which they are based). To use an unmodified Picture Control, highlight it and press ⓧ.

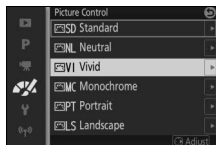

2 Adjust settings.

Press ▲ or ▼ to highlight the desired setting and press ◀ or ▶ to choose a value. Repeat this step until all settings have been adjusted, or select

Quick adjust to choose a preset combination of settings. Default settings can be restored by pressing the  button.



3 Save changes and exit.

Press .

Preset Picture Controls Versus Custom Picture Controls

The Picture Controls supplied with the camera are referred to as *preset Picture Controls*. *Custom Picture Controls* are created through modifications to existing Picture Controls using the **Custom Picture Control** option in the image processing menu (□ 206). If desired, custom Picture Controls can be saved to a memory card and copied to other Nikon 1 V3 cameras or loaded into compatible software (□ 207).

Modified Picture Controls

Picture Controls that have been modified from default settings are indicated by an asterisk ("*") in the Picture Control menu (□ 202) and in the detailed display (□ 6).

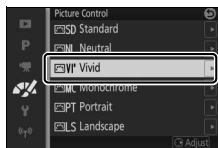

Picture Control Settings



Quick adjust		Mute or exaggerate the effect of the selected Picture Control (note that this resets all manual adjustments). Not available with Neutral , Monochrome , or custom Picture Controls.
Manual adjustments (all Picture Controls)	Sharpening	Manually adjust the sharpness of outlines, or select A to adjust sharpness automatically.
	Contrast	Adjust contrast manually, or select A for automatic contrast adjustment.
	Brightness	Adjust brightness without affecting exposure.
Manual adjustments (non-monochrome only)	Saturation	Control the vividness of colors. Select A to adjust saturation automatically.
	Hue	Adjust hue.
Manual adjustments (monochrome only)	Filter effects	Simulate the effect of color filters on monochrome photographs.
	Toning	Choose the tint used in monochrome photographs.

"A" (Auto)

Results for auto sharpening, contrast, and saturation vary with exposure and the size and position of the subject in the frame.



Previous Settings

The line under the value displayed in the Picture Control setting menu indicates the previous value for the setting. Use this as a reference when adjusting settings.



Filter Effects (Monochrome Only)

The options in this menu simulate the effect of color filters on monochrome photographs. The following filter effects are available:

Y (yellow)	Enhance contrast. Can be used to reduce the brightness of
O (orange)	the sky in landscape photographs. Orange produces more
R (red)	contrast than yellow, red more contrast than orange.
G (green)	Softens skin tones. Can be used for portraits.

Note that the effects achieved with **Filter effects** are more pronounced than those produced by physical glass filters.

Toning (Monochrome Only)

Choose from **B&W** (black-and-white), **Sepia**, **Cyanotype** (blue-tinted monochrome), **Red**, **Yellow**, **Green**, **Blue Green**, **Blue**, **Purple**, **Blue**, **Red Purple**. Pressing **▼** when **Toning** is highlighted displays saturation options. Press **◀** or **▶** to adjust saturation. Saturation control is not available when **B&W** (black-and-white) is selected.



Custom Picture Control

The Picture Controls supplied with the camera can be modified and saved as custom Picture Controls.

Edit/Save

To create a custom Picture Control, select **Edit/save** and follow the steps below.

1 Select a Picture Control.

Highlight an existing Picture Control and press **▶**, or press **OK** to proceed to Step 3 to save a copy of the highlighted Picture Control without further modification.

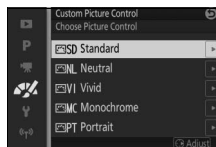

2 Edit the selected Picture Control.

See page 204 for more information. To abandon any changes and start over from default settings, press the **⌫** button. Press **OK** when settings are complete.

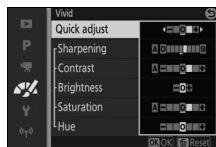

3 Save the Picture Control.

Highlight a destination (C-1 through C-9) and press **OK** to save the custom Picture Control and return to the image processing menu.

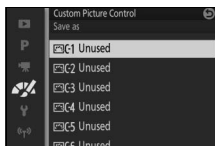

The new Picture Control will be listed in the **Picture Control** menu.

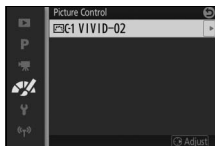

Load from/Save to Card

Custom Picture Controls created using the Picture Control Utility available with ViewNX 2 or optional software such as Capture NX 2 can be copied to a memory card and loaded into the camera, or custom Picture Controls created with the camera can be copied to the memory card to be used in other Nikon 1 V3 cameras and compatible software and then deleted when no longer needed.

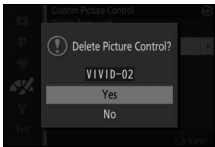

To copy custom Picture Controls to or from the memory card, or to delete custom Picture Controls from the memory card, select **Load from/save to card** in the **Custom Picture Control** menu. The following options will be displayed:

Copy to camera	Copy custom Picture Controls from the memory card to custom Picture Controls C-1 through C-9.
Delete from card	Delete selected custom Picture Controls from the memory card. The confirmation dialog shown at right will be displayed before a Picture Control is deleted; to delete the selected Picture Control, highlight Yes and press OK . 
Copy to card	Copy a custom Picture Control (C-1 through C-9) to a selected destination (1 through 99) on the memory card.

Copy to Card

Up to 99 custom Picture Controls can be stored on the memory card at any one time. The memory card can only be used to store user-created custom Picture Controls. The preset Picture Controls supplied with the camera can not be copied to the memory card or deleted.

Custom Picture Control > Delete

The **Delete** option in the **Custom Picture Control** menu can be used to delete selected custom Picture Controls from the camera when they are no longer needed.

High ISO Noise Reduction

Select **On** to reduce “noise” (randomly-spaced bright pixels, lines, or fog). If **Off** is selected, noise reduction will still be performed, but the amount is less than that performed when **On** is selected.





The Setup Menu

To display the setup menu, press MENU and select **Setup**.

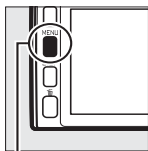

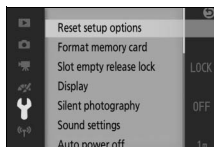
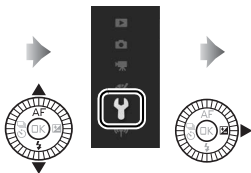

MENU button



The setup menu contains the following options:

Option	Description	Default	
Reset setup options	Reset setup menu options other than Flicker reduction , Time zone and date , and Language to default values.	—	—
Format memory card	Format the memory card.	—	211
Slot empty release lock	Allow the shutter to be released when no memory card is inserted in the camera.	Release locked	211
Display	Adjust display brightness, view or hide a framing grid, and choose the information displayed in the monitor.	Display brightness: 0 Viewfinder brightness ¹ : 0 Grid display: Off Playback highlight display: Off	211
Silent photography	Mute the sounds made during shooting.	Off	212
Sound settings	Choose the beeps made by the camera.	AF: On Self-timer: On Touch-screen controls: On	212
Auto power off	Choose the auto power off delay.	1 min	213
Touch-screen controls	Enable or disable touch-screen controls (17).	Enable	—



Option	Description	Default	
Remote on duration	Choose how long the camera waits for a signal from an ML-L3 remote control.	10 min	213
Assign Fn button	Choose the roles played by the Fn1 , Fn2 , and Fn3 buttons.	Fn1: White balance Fn2: ISO sensitivity Fn3: Movie-record button ²	14
Assign AE/AF-L button	Choose the role played by the  button.	AE/AF lock	214
Shutter button AE lock	Choose whether exposure locks when the shutter-release button is pressed half-way.	Off	—
HDMI device control	Choose whether remote controls for HDMI-CEC devices to which the camera is connected can be used to operate the camera.	On	149
Flicker reduction	Reduce flicker or banding.	—	217
Reset file numbering	Reset file numbering.	—	218
Time zone and date	Set the camera clock.	Daylight saving time: Off	218
Language	Choose a language for the camera displays.	—	—
Auto image rotation	Record camera orientation with pictures.	On	219
Location data	Adjust settings for optional GPS units.	Auto power off: Disable Set clock from satellite: Yes	114
Pixel mapping	Check and optimize the camera image sensor and image processors.	—	220
Firmware version	Display the current firmware version.	—	—

1 Available only when optional electronic viewfinder is attached.

2 Available only when optional grip is attached.



Format Memory Card

Select **Yes** to format the memory card. *Note that this permanently deletes all data on the card, including protected images; before proceeding, be sure to copy important pictures and other data to a computer (📖 145).* To exit without formatting the memory card, highlight **No** and press **OK**.

The message shown at right is displayed while the card is formatted; *do not remove the memory card or remove or disconnect the power source until formatting is complete.*

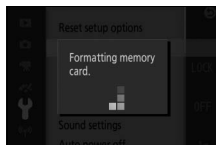

Slot Empty Release Lock

If **Enable release** is selected, the shutter can be released when no memory card is inserted. No pictures will be recorded, although they will be displayed in demo mode. Select **Release locked** to enable the shutter only when a card is inserted.

Display

Adjust the following display options.

Display Brightness

To adjust the brightness of the monitor, select **Display brightness** and press **▲** or **▼**. Choose higher values to brighten the display and lower values to make the display darker.

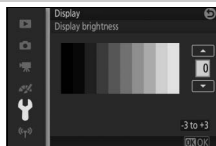

Viewfinder Brightness

This option is available only when an optional viewfinder is attached. To adjust the brightness of the viewfinder, select **Viewfinder brightness** and press ▲ or ▼. Choose higher values to brighten the display and lower values to make the display darker.

Grid Display

Select **On** to display a framing grid (📖 40).

Playback Highlight Display

Choose whether to display highlights (📖 131) in full frame playback.

Silent Photography

Select **On** to reduce camera noise in quiet surroundings. The camera uses an electronic shutter and silences the sounds produced when the camera controls are operated. Selecting **Off** restores normal operation; a mechanical shutter is used except when a frame rate of 10 fps or higher is selected in continuous shooting mode (📖 92).

Sound Settings

Highlight items and press ► to select or deselect. Select **AF** to sound a beep when the camera focuses, **Self-timer** to sound a beep during self-timer photography, **Touch-screen controls** to sound a beep in response to use of the touch-screen controls, or remove the checks to mute these sounds. Press Ⓚ to exit when settings are complete.

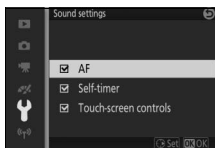

Auto Power Off

Choose how long the displays remain on when no operations are performed (📖 29). Choose shorter delays to reduce the drain on the battery. Once the displays have turned off, they can be reactivated by pressing the shutter-release button.

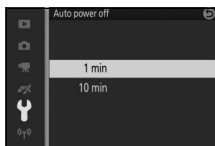

The GP-N100

To enable auto power off when an optional GP-N100 GPS unit is attached, select **Enable** for the **Location data** > **Auto power off** option in the setup menu (📖 114).

Remote on Duration

Choose how long the camera will remain active while waiting for a signal from the remote control (📖 96). Choose a shorter delay to reduce the drain on the battery. Note that remote control mode must be reselected once the timer has expired.

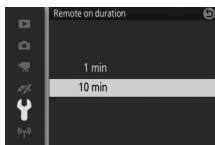

Assign AE/AF-L Button

Choose whether the AE-L/AF-L button locks both focus and exposure (**AE/AF lock**), exposure only (**AE lock only**), or focus only (**AF lock only**) or can be used to initiate autofocus (**AF-ON**). Exposure lock is described below, focus lock on page 216.

Autoexposure Lock

Exposure lock is used to recompose photographs after metering exposure. It is most effective when used with center-weighted or spot metering (☐ 177) to frame off-center subjects that are much brighter or darker than their surroundings or to optimize exposure for an object other than your main subject.

1 Meter exposure.

Position the subject in the center of the frame and press the shutter-release button halfway to meter exposure. Check that the focus area is displayed in green.

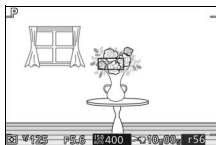

2 Lock exposure.

With the shutter-release button pressed halfway and the subject positioned in the focus area, press the **AE-L/AF-L** button to lock exposure. While exposure lock is in effect, an **AE-L/AF-L** indicator will be displayed. Exposure will remain locked while the button is pressed.

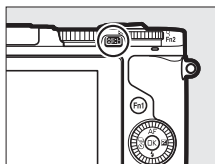

AE-L/AF-L button

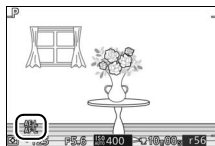

3 Recompose the photograph.

Recompose the photograph and shoot.

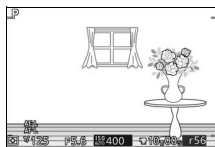

Focus Lock

Focus lock can be used to change the composition after focusing on the subject in the center of the frame, allowing you to focus on a subject that will not be in the center of the final composition. If the camera is unable to focus using autofocus (📖 101), you can also focus on another subject at the same distance and then use focus lock to recompose the photograph. Focus lock is most effective when an option other than **Auto-area** is selected for **AF-area mode** (📖 185).

1 Focus.

Position the subject in the center of the frame and press the shutter-release button halfway to initiate focus. Check that the focus area is displayed in green. If **AF-S** is selected for focus mode (📖 99), focus will lock while the shutter-release button is pressed halfway.

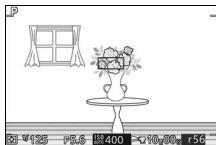

2 Lock focus.

Press the **AE-L/AF-L** button to lock focus and confirm that **AE-L/AF-L** appears in the display. Focus will remain locked while the button is pressed.

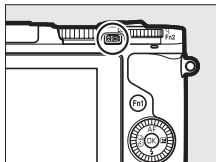

AE-L/AF-L button

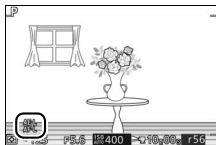

3 Recompose the photograph and shoot.

Focus will remain locked between shots.

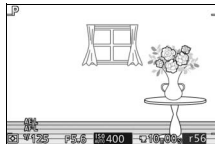

Do not change the distance between the camera and the subject while focus lock is in effect. If the subject moves, focus again at the new distance.

Flicker Reduction

Reduce flicker and banding in the display and in movies while shooting under fluorescent or mercury-vapor lighting. Choose a frequency which matches that of the local AC power supply.

Flicker Reduction

If you are unsure as to the frequency of the local power supply, test both options and choose the one that produces the best results. Flicker reduction may not produce the desired results if the subject is very bright, in which case you should select mode A or M and choose a smaller aperture (higher f-number).



Reset File Numbering

When a photograph is taken or a movie is recorded, the camera names the file by adding one to the number of the previous file (📖 173). If the current folder is numbered 999 and contains either 999 photographs or a photograph numbered 9999, the shutter-release button will be disabled and no further photographs can be taken. To reset file numbering to 0001, select **Yes** for **Reset file numbering** and then either format the current memory card or insert a new memory card.

Time Zone and Date

Change time zones, set the camera clock, choose the date display order, or turn daylight saving time on or off (📖 31).

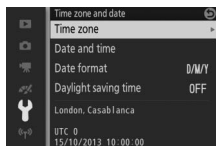

Time zone	Choose a time zone. The camera clock is automatically set to the time in the new time zone.
Date and time	Set the camera clock.
Date format	Choose the order in which the day, month, and year are displayed.
Daylight saving time	Turn daylight saving time on or off. The camera clock will automatically be advanced or set back one hour. The default setting is Off .



Auto Image Rotation

Photographs taken while **On** is selected contain information on camera orientation, allowing them to be rotated automatically during playback or when viewed in ViewNX 2 (supplied) or Capture NX 2 (available separately;  223). The following orientations are recorded:

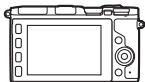

*Landscape (wide)
orientation*

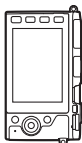

*Camera rotated 90°
clockwise*

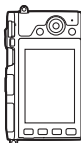

*Camera rotated 90°
counterclockwise*

Camera orientation is not recorded when **Off** is selected. Choose this option when panning or taking photographs with the lens pointing up or down.

Auto Image Rotation

Image orientation is not recorded for movies, Motion Snapshots, or panoramas.

Rotate Tall

To automatically rotate "tall" (portrait-orientation) photographs for display during playback, select **On** for the **Rotate tall** option in the playback menu ( 159).



Pixel Mapping

Check and optimize the camera image sensor and image processors if you notice unexpected bright spots in your pictures (note that the camera comes with the sensor and processors already optimized). Before performing pixel mapping as described below, check that the battery is fully charged.

1 Attach a lens and lens cap.

Turn the camera off and attach a 1 NIKKOR lens. If the lens is equipped with a cap, do not remove it.

2 Select Pixel mapping.

Turn the camera on, press **MENU**, and select **Pixel mapping** in the setup menu.

3 Select Yes.

Pixel mapping begins immediately. Note that other operations can not be performed while pixel mapping is in progress. *Do not turn the camera off or remove or disconnect the power source until pixel mapping is complete.*

4 Turn the camera off.

Turn the camera off when pixel mapping is complete.



Technical Notes

Read this chapter for information on compatible accessories, cleaning and storing the camera, and what to do if an error message is displayed or you encounter problems using the camera.

Optional Accessories

At the time of writing, the following accessories were available for your camera.

Lenses	1 mount lenses
Mount adapters	Mount Adapter FT1: The FT1 allows NIKKOR F mount lenses to be used with Nikon 1 interchangeable lens format digital cameras. The angle of view of an F mount lens mounted on the FT1 is equivalent to that of a 35 mm format lens with a focal length about 2.7 × longer. See page 259 for information on using the FT1; be sure to update to the latest version of the FT1 firmware before use. For information on attaching and removing the FT1 and on precautions for use, see the <i>FT1 Mount Adapter User's Manual</i> . For information on the lenses that can be used, see <i>Compatible NIKKOR F Mount Lenses</i> . The <i>FT1 Mount Adapter User's Manual</i> and <i>Compatible NIKKOR F Mount Lenses</i> are included with the FT1.
Electronic viewfinders	Electronic Viewfinder DF-N1000 (□ 34): The DF-N1000 connects to the camera multi accessory port.
Grips	Grip GR-N1010 (□ 36): The GR-N1010 offers improved handling and is equipped with a sub-command dial and shutter-release and Fn3 buttons.

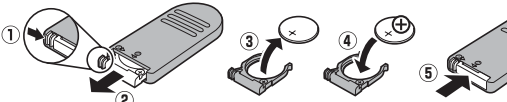

Power sources	<ul style="list-style-type: none"> • Rechargeable Li-ion Battery EN-EL20a (□ 23–24): Additional EN-EL20a batteries are available from local retailers and Nikon-authorized service representatives. • Battery Charger MH-29 (□ 23): Recharge EN-EL20a batteries. • Power Connector EP-5C, AC Adapter EH-5b: These accessories can be used to power the camera for extended periods (EH-5a and EH-5 AC adapters can also be used). An EP-5C power connector is required to connect the camera to the EH-5b, EH-5a, or EH-5; see page 225 for details.
Flash units	<p>When mounted on the Nikon 1 V3, the following flash units support i-TTL and manual flash control (□ 187).</p> <ul style="list-style-type: none"> • Speedlight SB-N5 (□ 109): The SB-N5 has a Guide Number of 8.5/27.9 (m/ft, ISO 100, 20 °C/68 °F; Guide Number at ISO 160 is 10.8/35.4). • Speedlight SB-N7 (□ 109): The SB-N7 has a Guide Number of 18/59 (m/ft, ISO 100, 20 °C/68 °F; Guide Number at ISO 160 is 22.8/74.8).
Remote controls	<p>Wireless Remote Control ML-L3 (□ 96): The ML-L3 uses a 3 V CR2025 battery.</p>  <p>Pressing the battery-chamber latch to the right (①), insert a fingernail into the gap and open the battery chamber (②). Ensure that the battery is in the correct orientation (④).</p>
Micro-phones	<p>Stereo Microphone ME-1 (□ 193): Connect the ME-1 to the camera microphone jack to record stereo sound while reducing the noise caused by lens vibration being recorded during autofocus.</p>



Multi accessory port accessories	Multi Accessory Port Adapter AS-N1000: The AS-N1000 fixes optional ME-1 stereo microphones to the Nikon 1 V3.
GPS units	GPS Unit GP-N100 (☐ 113): Record the time (UTC) and the camera's current latitude, longitude, and altitude with every picture taken.
Software	<p>Capture NX 2: A complete photo editing package offering such features as white balance adjustment and color control points.</p> <p>Note: Use the latest versions of Nikon software; see the websites listed on page xviii for the latest information on supported operating systems. At default settings, Nikon Message Center 2 will periodically check for updates to Capture NX 2 and other Nikon software and firmware while you are logged in to an account on the computer and the computer is connected to the Internet. A message is automatically displayed when an update is found.</p>
Body caps	Body Cap BF-N1000: The body cap keeps the dust shield free of dust when a lens is not in place.

Optional Accessories

Availability may vary with country or region. See our website or brochures for the latest information.



Approved Memory Cards

The following cards have been tested and approved for use in the camera. Cards with class 6 or faster write speeds are recommended for movie recording. Recording may end unexpectedly when cards with slower write speeds are used.

	microSD cards	microSDHC cards ²	microSDXC cards ³
SanDisk	2 GB ¹	4 GB, 8 GB, 16 GB, 32 GB	64 GB
Toshiba			—
Panasonic			—

- 1 Check that any card readers or other devices with which the card will be used support 2 GB cards.
- 2 Check that any card readers or other devices with which the card will be used are SDHC-compliant. The camera supports UHS-I.
- 3 Check that any card readers or other devices with which the card will be used are SDXC-compliant. The camera supports UHS-I.



Other cards have not been tested. For more details on the above cards, please contact the manufacturer.

Attaching a Power Connector and AC Adapter

Turn the camera off before attaching an optional power connector and AC adapter.

1 Ready the camera.

Open the battery-chamber and power connector covers.

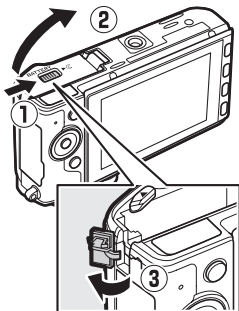

2 Insert the EP-5C power connector.

Be sure to insert the connector in the orientation shown, using the connector to keep the orange battery latch pressed to one side. The latch locks the connector in place when the connector is fully inserted.

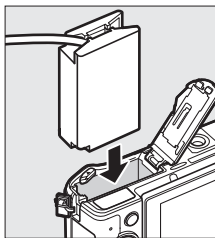

3 Close the battery-chamber cover.

Position the power connector cable so that it passes through the power connector slot and close the battery-chamber cover.

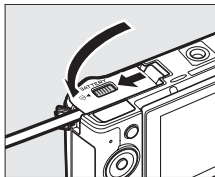

4 Connect the AC adapter.

Connect the AC adapter power cable to the AC socket on AC adapter (①) and the EP-5C power cable to the DC socket (②). A  icon is displayed in the monitor when the camera is powered by the AC adapter and power connector.

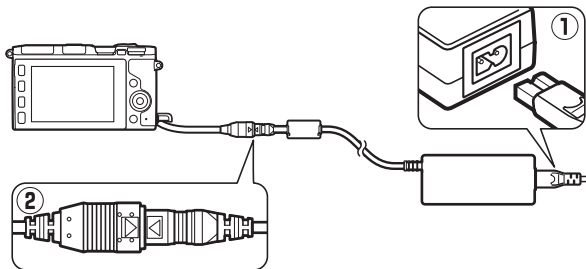

Storage and Cleaning

Storage

If the camera will not be used for an extended period, remove the battery and store it in a cool, dry area with the terminal cover in place. To prevent mold or mildew, store the camera in a dry, well-ventilated area. Do not store your camera with naphtha or camphor moth balls or in locations that:

- are poorly ventilated or subject to humidities of over 60%
- are next to equipment that produces strong electromagnetic fields, such as televisions or radios
- are exposed to temperatures above +50 °C (122 °F) or below -10 °C (14 °F)

Cleaning

Camera body	Use a blower to remove dust and lint, then wipe gently with a soft, dry cloth. After using the camera at the beach or sea-side, wipe off sand or salt with a cloth lightly dampened in distilled water and dry thoroughly. Important: <i>Dust or other foreign matter inside the camera may cause damage not covered under warranty.</i>
Lens, viewfinder	These elements are easily damaged. Remove dust and lint with a blower. If using an aerosol blower, keep the can vertical to prevent the discharge of liquid. To remove fingerprints and other stains, apply a small amount of lens cleaner to a soft cloth and clean with care.
Monitor	Remove dust and lint with a blower. When removing fingerprints and other stains, wipe the surface lightly with a soft cloth or chamois leather. Do not apply pressure, as this could result in damage or malfunction.
Dust shield	The dust shield is easily damaged. Remove dust and lint with a blower.

Do not use alcohol, thinner, or other volatile chemicals.



Caring for the Camera and Battery: Cautions

Do not drop: The product may malfunction if subjected to strong shocks or vibration.

Keep dry: This product is not waterproof, and may malfunction if immersed in water or exposed to high levels of humidity. Rusting of the internal mechanism can cause irreparable damage.

Avoid sudden changes in temperature: Sudden changes in temperature, such as those that occur when entering or leaving a heated building on a cold day, can cause condensation inside the device. To prevent condensation, place the device in a carrying case or plastic bag before exposing it to sudden changes in temperature.

Keep away from strong magnetic fields: Do not use or store this device in the vicinity of equipment that generates strong electromagnetic radiation or magnetic fields. Strong static charges or the magnetic fields produced by equipment such as radio transmitters could interfere with the display, damage data stored on the memory card, or affect the product's internal circuitry.

Keep the lens mount covered: Be sure to attach the body cap if the camera is without a lens.

Do not touch the dust shield: The dust shield covering the image sensor is easily damaged. Under no circumstances should you exert pressure on the shield or poke it with cleaning tools. These actions could scratch or otherwise damage the shield.

Turn the product off before removing or disconnecting the power source: Do not unplug the product or remove the battery while the product is on or while images are being recorded or deleted. Forcibly cutting power in these circumstances could result in loss of data or in damage to product memory or internal circuitry. To prevent an accidental interruption of power, avoid carrying the product from one location to another while the AC adapter is connected.



Cleaning: When cleaning the camera body, use a blower to gently remove dust and lint, then wipe gently with a soft, dry cloth. After using the camera at the beach or seaside, wipe off any sand or salt using a cloth lightly dampened in pure water and then dry the camera thoroughly.

Lenses, viewfinders, and other glass elements are easily damaged. Dust and lint should be gently removed with a blower. When using an aerosol blower, keep the can vertical to prevent discharge of liquid. To remove fingerprints and other stains from the glass, apply a small amount of lens cleaner to a clean, soft cloth and wipe the glass carefully.

Storage: To prevent mold or mildew, store the camera in a cool, dry, well-ventilated area. If you are using an AC adapter, unplug the adapter to prevent fire. If the product will not be used for an extended period, remove the battery to prevent leakage and store the camera in a plastic bag containing a desiccant. Do not, however, store the camera case in a plastic bag, as this may cause the material to deteriorate. Note that desiccant gradually loses its capacity to absorb moisture and should be replaced at regular intervals.

To prevent mold or mildew, take the camera out of storage at least once a month. Turn the camera on and release the shutter a few times before putting it away.

Store the battery in a cool, dry place. Replace the terminal cover before putting the battery away.

Notes on the monitor and viewfinder: These displays are constructed with extremely high precision; at least 99.99% of pixels are effective, with no more than 0.01% being missing or defective. Hence while these displays may contain pixels that are always lit (white, red, blue, or green) or always off (black), this is not a malfunction and has no effect on images recorded with the device.

Images in the monitor may be difficult to see in a bright light.

Do not apply pressure to the display, as this could cause damage or malfunction. Dust or lint on the display can be removed with a blower. Stains can be removed by wiping lightly with a soft cloth or chamois leather. Should the monitor break, care should be taken to avoid injury from broken glass and to prevent liquid crystal from the display touching the skin or entering the eyes and mouth.



Do not leave the lens pointed at the sun: Do not leave the lens pointed at the sun or other strong light source for an extended period. Intense light may cause the image sensor to deteriorate or produce a white blur effect in photographs.

Moiré: Moiré is an interference pattern created by the interaction of an image containing a regular, repeating grid, such as the pattern of weave in cloth or windows in a building, with the camera image sensor grid. In some cases, it may appear in the form of lines. If you notice moiré in your photographs, try changing the distance to the subject, zooming in and out, or changing the angle between the subject and the camera.

Lines: Noise in the form of lines may in rare cases appear in pictures of extremely bright or backlit subjects.

Batteries: Batteries may leak or explode if improperly handled. Observe the following precautions when handling batteries:

- Use only batteries approved for use in this equipment.
- Do not expose the battery to flame or excessive heat.
- Keep the battery terminals clean.
- Turn the product off before replacing the battery.
- Remove the battery from the camera or charger when not in use and replace the terminal cover. These devices draw minute amounts of charge even when off and could draw the battery down to the point that it will no longer function. If the battery will not be used for some time, insert it in the camera and run it flat before removing it and storing it in a location with an ambient temperature of 15 °C to 25 °C (59 °F to 77 °F; avoid hot or extremely cold locations). Repeat this process at least once every six months.
- Turning the camera on and off repeatedly when the battery is fully discharged will shorten battery life. Batteries that have been fully discharged must be charged before use.
- The internal temperature of the battery may rise while the battery is in use. Attempting to charge the battery while the internal temperature is elevated will impair battery performance, and the battery may not charge or charge only partially. Wait for the battery to cool before charging.



- Continuing to charge the battery after it is fully charged can impair battery performance.
- A marked drop in the time a fully charged battery retains its charge when used at room temperature indicates that it requires replacement. Purchase a new EN-EL20a battery.
- Charge the battery before use. When taking photographs on important occasions, ready a spare EN-EL20a battery and keep it fully charged. Depending on your location, it may be difficult to purchase replacement batteries on short notice. Note that on cold days, the capacity of batteries tends to decrease. Be sure the battery is fully charged before taking photographs outside in cold weather. Keep a spare battery in a warm place and exchange the two as necessary. Once warmed, a cold battery may recover some of its charge.
- Used batteries are a valuable resource; recycle in accord with local regulations.

Servicing the Camera and Accessories











The camera is a precision device and requires regular servicing. Nikon recommends that the camera be inspected by the original retailer or Nikon-authorized service representative once every one to two years, and that it be serviced once every three to five years (note that fees apply to these services). Frequent inspection and servicing are particularly recommended if the camera is used professionally. Any accessories regularly used with the camera, such as lenses, should be included when the camera is inspected or serviced.



Available Settings

The following table lists the settings that can be adjusted in each mode.

Auto, Best Moment Capture, Advanced Movie, and Motion Snapshot Modes

												
							P, S,	A	M		P, S,	A
Shooting, movie, and image processing menus	Image quality	✓ ¹	✓	✓	✓	—	—	—	—	—	—	—
	Image size ²	✓ ¹	✓	✓	✓	—	—	—	—	—	—	—
	Metering	—	✓ ³	✓ ³	—	—	✓ ⁴	✓ ⁴	—	✓	✓	—
	Auto distortion control	✓ ¹	✓	✓	✓	—	—	—	—	—	—	—
	Color space	✓ ¹	✓	✓	✓	—	—	—	—	—	—	—
	Active D-Lighting	—	✓ ³	✓ ³	—	—	—	—	—	—	—	—
	Long exposure NR	✓ ⁵	—	—	—	—	—	—	—	—	—	—
	Interval timer shooting	—	—	—	—	—	—	—	—	—	—	—
	Focus mode	—	✓ ³	✓ ³	—	—	✓	✓	—	—	—	—
	AF-area mode	—	✓ ³	✓ ³	—	—	✓ ⁴	✓ ⁴	—	✓	✓	—
	Face-priority	—	✓ ³	✓ ³	—	—	✓ ⁴	✓ ⁴	—	✓	✓	—
	Flash compensation	—	—	—	—	—	—	—	—	—	—	—
	White balance	—	✓ ³	✓ ³	—	—	✓	✓	—	✓	✓	—
	ISO sensitivity	—	✓ ³	✓ ³	—	—	✓	✓	—	✓	✓	—
	Picture Control	—	✓ ³	✓ ³	—	—	✓	✓	—	✓	✓	—
	Custom Picture Control	—	✓ ³	✓ ³	—	—	✓	✓	—	✓	✓	—
	High ISO noise reduction	✓	✓	✓	✓	✓	✓	✓	✓	✓	✓	✓



		[+] (Crop)				[+] (Slow motion)			[+] (Scene)		
		[Camera]	[Movie]	[Still]	[Still]	SCENE	P, S,		SCENE	P, S,	
							A	M		A	M
Other settings	Autoexposure lock	—	✓ ³	✓ ³	—	—	✓	✓	—	✓	✓
	Focus lock	—	✓ ³	✓ ³	—	—	✓	✓	—	✓	✓
	Continuous	✓	—	—	—	—	—	—	—	—	—
	Self-timer	✓	—	—	—	✓	✓	✓	—	—	—
	Remote control	✓	—	—	—	✓	✓	✓	—	—	—
	Exposure compensation	✓	✓ ⁶	✓ ⁶	—	✓	✓	—	✓	✓	—
	Flash mode	✓ ⁵	—	—	—	—	—	—	—	—	—

1 Has no effect on movies recorded with movie-record button.

2 RAW images fixed at 5232 × 3488 pixels.

3 Available when P, S, A, or M is selected for **Exposure mode**.









4 Not available when  **Slow motion** is selected in advanced movie mode (□ 62).









5 Not available when 10, 20, 30, or 60 fps is selected in continuous mode (□ 92).

6 Available when , P, S, or A is selected for **Exposure mode**.



■ P, S, A, M, and Creative Modes

In the table below, creative modes are represented by the following icons:  creative palette,  HDR,  easy panorama,  soft,  miniature effect,  selective color,  cross process, and  toy camera effect.

	P, S, A	M				    	
Shooting, movie, and image processing menus	Image quality	✓ ¹	✓ ¹	✓ ^{1,2}	✓ ^{1,2}	✓ ^{1,2}	✓ ^{1,2}
	Image size	✓ ^{1,3}	✓ ^{1,3}	✓ ¹	✓ ¹	✓ ¹	✓ ¹
	Metering	✓ ¹	✓ ¹	—	—	—	—
	Auto distortion control	✓ ¹	✓ ¹	✓ ¹	✓ ¹	—	✓ ¹
	Color space	✓ ¹	✓ ¹	✓ ¹	✓ ¹	✓	✓ ¹
	Active D-Lighting	✓ ¹	✓ ¹	—	—	—	—
	Long exposure NR	✓ ⁴	✓ ⁴	—	—	—	—
	Interval timer shooting	✓	✓	—	—	—	—
	Focus mode	✓ ¹	✓ ¹	—	—	—	—
	AF-area mode	✓ ¹	✓ ¹	—	—	—	—
	Face-priority	✓	✓	—	—	—	—
	Flash compensation	✓ ⁴	✓ ⁴	—	—	—	✓
	White balance	✓	✓	—	—	—	—
	ISO sensitivity	✓ ¹	✓ ¹	—	—	—	—
	Picture Control	✓	✓	—	—	—	—
	Custom Picture Control	✓	✓	—	—	—	—
High ISO noise reduction	✓	✓	—	—	—	—	
Other settings	Autoexposure lock	✓	✓	—	✓	✓	✓
	Focus lock	✓	✓	✓	✓	✓	✓
	Continuous	✓	✓	—	—	—	—
	Self-timer	✓	✓	✓	✓	—	✓
	Remote control	✓	✓	✓	✓	—	✓
	Exposure compensation	✓	—	—	✓	✓	✓
	Flash mode	✓ ⁴	✓ ⁴	—	—	—	✓

1 Has no effect on movies recorded with movie-record button.

2 **NEF (RAW)** and **NEF (RAW) + JPEG fine** not available.

3 RAW images fixed at 5232 × 3488 pixels.

4 Not available when 10, 20, 30, or 60 fps is selected in continuous mode (□ 92).



Defaults

Defaults for the options in the playback, shooting, movie, image processing, and setup menus may be found on pages 156, 167, 189, 195, and 209, respectively. Defaults for other settings are listed below.

Option	Default
Focus area (☐ 185)	Center*
Flexible program (☐ 70)	Off
Autoexposure lock (☐ 214)	Off
Focus lock (☐ 216)	Off
Continuous/self-timer/remote control (☐ 92, 94, 96)	 (single frame)
Exposure compensation (☐ 104)	0.0
Flash mode (☐ 106)	Fill flash
Picture Control settings (☐ 202)	Unmodified

* Not displayed when **Auto-area** is selected for **AF-area mode** (☐ 185).



Memory Card Capacity

The following table shows the number of pictures or amount of movie footage that can be stored on a 16GB SanDisk SDSDQXP-016G-J35 UHS-I microSDHC card at different image quality, size, or movie settings. All figures are approximate; file size varies with the type of card and scene recorded.

■ Auto, Creative (Easy Panorama Excluded), P, S, A, M, Active Selection, Slow View, and Smart Photo Selector¹

Image quality (☐ 171)	Image size (☐ 172)	File size	No. of images
NEF (RAW) + JPEG fine ²	5232 × 3488	35.3 MB	430
	3920 × 2616	30.7 MB	494
	2608 × 1744	27.5 MB	552
NEF (RAW)	—	24.3 MB	625
JPEG fine	5232 × 3488	11.0 MB	1300
	3920 × 2616	6.5 MB	2300
	2608 × 1744	3.2 MB	4700
JPEG normal	5232 × 3488	5.8 MB	2600
	3920 × 2616	3.5 MB	4300
	2608 × 1744	1.9 MB	7900

1 Off selected for **Silent photography** and **Number of shots saved** set to 1.

2 Image size applies to JPEG images only. Size of NEF (RAW) images can not be changed. File size is the total for NEF (RAW) and JPEG images.



Easy Panorama

Image quality (□ 171)	Image size (□ 172)		File size	No. of images
JPEG fine	Normal panorama	4800 × 920	4.4 MB	3400
		1536 × 4800	4.4 MB	3400
	Wide panorama	9600 × 920	8.6 MB	1700
		1536 × 9600	8.6 MB	1700
JPEG normal	Normal panorama	4800 × 920	2.3 MB	6500
		1536 × 4800	2.3 MB	6500
	Wide panorama	9600 × 920	4.4 MB	3400
		1536 × 9600	4.4 MB	3400

Smart Photo Selector¹

Image quality (□ 171)	Image size (□ 172)	File size	No. of shots
NEF (RAW) + JPEG fine ²	5232 × 3488	176.5 MB	86
	3920 × 2616	153.6 MB	98
	2608 × 1744	137.3 MB	110
NEF (RAW)	—	121.4 MB	125
JPEG fine	5232 × 3488	55.1 MB	275
	3920 × 2616	32.3 MB	469
	2608 × 1744	15.9 MB	952
JPEG normal	5232 × 3488	29.0 MB	522
	3920 × 2616	17.6 MB	860
	2608 × 1744	9.4 MB	1500

1 Number of shots saved set to 5. File size is total for 5 images.

2 Image size applies to JPEG images only. Size of NEF (RAW) images can not be changed. File size is the total for NEF (RAW) and JPEG images.



■ HD, Fast-Motion, Jump-Cut, and 4-Second Movies

Frame size/frame rate (☐ 192) ¹	Maximum total length (approx.) ²
1080/60p	47 minutes
1080/30p	1 hour 20 minutes
720/60p	1 hour 57 minutes
720/30p	2 hours 32 minutes

1 HD movies only. Fast-motion, jump-cut, and 4-second movies are recorded at 1080/30p.

2 For information on the maximum length that can be recorded in a single clip, see page 192.

■ Slow-Motion Movies

Frame rate (☐ 191)	Maximum total recorded length (approx.) [*]
120 fps	26 minutes
400 fps	31 minutes
1200 fps	31 minutes

^{*} Up to 3 s of slow-motion footage can be recorded in a single clip. Playback length is about 4 (**120 fps**) or 13 (**400 fps**) or 40 (**1200 fps**) times the recorded length.

■ Motion Snapshots

Image quality	Image size	Format (☐ 176)	File size	No. of shots
—	—	NMS	23.6 MB [*]	641
—	—	MOV	32.5 MB	467

^{*} File size is the total for a single photograph and movie.



Troubleshooting

If the camera fails to function as expected, check this list of common problems before consulting your retailer or Nikon representative.

Battery/Display

The camera is on but does not respond: Wait for recording or any other processing to end. If the problem persists, turn the camera off. If the camera still does not respond, remove and replace the battery or disconnect and reconnect the AC adapter, but note that this will delete any data not yet saved. Data already saved to the memory card are unaffected.

The displays are off:

- The camera is off (☐ 29) or the battery is exhausted (☐ 23, 33).
- An object has come close to the eye sensor, turning the optional viewfinder on and the monitor off (☐ 35).
- The displays have turned off automatically to save power (☐ 29). The displays can be reactivated by pressing the shutter-release button.
- The camera is connected to a computer (☐ 145) or television (☐ 148).

The viewfinder is out of focus: Focus the viewfinder using the diopter adjustment control (☐ 35).

The camera turns off without warning:

- The battery is low (☐ 23, 33).
- The display has turned off automatically to save power (☐ 29). The display can be reactivated by pressing the shutter-release button.
- The camera's internal temperature is high (☐ xvii, 246). Wait for the camera to cool before turning it on again.

Indicators are not displayed: Press the DISP button (☐ 6).



Shooting (All Modes)

The camera takes time to turn on: Delete files or format the memory card.

The shutter-release is disabled:

- The battery is exhausted (☐ 23, 33).
 - The memory card is full (☐ 33).
 - The flash is charging (☐ 107).
 - The camera is not in focus (☐ 39).
 - You are currently filming a slow-motion movie (☐ 64).
-

Only one picture is taken each time the shutter-release button is pressed in continuous release mode:  is selected in continuous mode (☐ 92) and flash lighting is used.

The camera does not focus automatically:

- The subject is not suited to autofocus (☐ 101).
 - The camera is in manual focus mode (☐ 99, 102).
-

Focus does not lock when the shutter-release button is pressed halfway: Use the  button to lock focus when **AF-C** is selected for focus mode or when photographing moving subjects in **AF-A** mode (☐ 99, 216).

Focus area selection is unavailable: Focus area selection is not available in auto-area AF (☐ 185) or face priority (☐ 45). In other AF-area modes, the focus area can be selected by pressing .

AF-area mode selection is unavailable: The camera is in auto, creative (☐ 50), or best moment capture (☐ 76) mode, manual focus mode is selected (☐ 99), or the  **Scene auto selector** is used (☐ 170).

Image size selection is unavailable: An NEF (RAW) option is selected for image quality (☐ 171).

The camera is slow to record photos: Turn long exposure noise reduction off (☐ 180) and choose an option for ISO sensitivity (☐ 201) other than **6400 (NR)** and **12800 (NR)**. In creative mode, additional time may be needed to record photos when **HDR** or **Easy panorama** is selected (☐ 53, 54).

Noise (bright spots, randomly-spaced bright pixels, fog, or lines) appears in photos:

- Lower ISO sensitivity or enable high ISO noise reduction (☐ 208).
 - Use long exposure noise reduction at shutter speeds slower than 1 s (☐ 180).
-



No photo taken when ML-L3 remote control shutter-release button is pressed:

- Replace battery in remote control (□ 222).
- Choose a remote control mode (□ 96).
- The remote control standby timer has expired (□ 213).
- The remote is not pointed at the camera or the infrared receiver is not visible (□ 2, 96).
- The remote is too far from the camera (□ 97).
- Bright light is interfering with remote.

Smudges appear in photographs: Clean the front and rear lens elements or the dust shield (□ 227).

Flicker or banding appears in movies or in the display: Choose a **Flicker reduction** setting that matches the local AC power supply (□ 217).

No flash: The built-in flash and optional flash units will not fire during movie recording (□ 59) or live image control (□ 47), in best moment capture (□ 76), Motion Snapshot (□ 87), advanced movie (□ 62), creative palette (□ 52), or easy panorama (□ 54) modes, or when HDR is on (□ 53), a frame rate of 10 fps or higher is selected in continuous mode (□ 92), or **6400 (NR)** or **12800 (NR)** is selected for ISO sensitivity (□ 201).

Menu items are unavailable: Some options are only available in particular shooting or exposure modes (□ 232).

Shooting (P, S, A, and M Modes)

The shutter release is disabled: You selected mode **S** after choosing a shutter speed of “Bulb” or “Time” in mode **M** (□ 73). Choose a different shutter speed.

Some shutter speeds are not available: You are using the flash.

Colors are unnatural:

- Adjust white balance to match the light source (□ 196).
- Adjust Picture Control settings (□ 202).

Cannot measure white balance: The subject is too dark or too bright (□ 199).

Picture Controls produce varying results: **A** (auto) is selected for sharpening, contrast, or saturation. For consistent results over a series of photos, choose another setting (□ 204).

Metering can not be changed: Exposure lock is in effect (□ 214).

Noise (reddish areas and other artifacts) appears in long time-exposures: Enable long exposure noise reduction (□ 180).

Movies

Cannot record movies: The movie-record button can not be used to record movies in best moment capture or Motion Snapshot mode (☞ 79, 90).

No sound is recorded for movies:

- **Microphone off** is selected for **Movie sound options > Microphone** (☞ 193).
- Live audio is not recorded with slow-motion, fast-motion, or jump-cut movies (☞ 62) or with Motion Snapshots recorded with **None** selected for **Audio** (☞ 90).

Tap Shooting Options

The touch screen can not be used for shooting or focus:

- Touch shooting options are not available in best moment capture or Motion Snapshot mode.
- The edges of the display can not be used for shooting or focus. Tap closer to the center of the display.

Pictures are blurred: The camera may move when the display is tapped, which may under some conditions result in blurred pictures. Use both hands to hold the camera steady.

Playback

NEF (RAW) images are not displayed: The camera displays only the JPEG copies of NEF (RAW) + JPEG fine images (☞ 173).

“Tall” (portrait) orientation photos are displayed in “wide” (landscape) orientation:

- Select **On** for **Rotate tall** (☞ 159).
- The photos were taken with **Auto image rotation** off (☞ 219).
- Camera was pointed up or down when the photo was taken (☞ 219).
- Photo is displayed in image review (☞ 159).

Cannot hear movie sound:

- Rotate the main command dial right to raise the volume (☞ 65). If the camera is connected to a television (☞ 148), use the controls for the TV to adjust the volume.
 - You are blocking the speaker with a finger or other object (☞ 3). Remove the obstruction.
 - Live audio is not recorded with slow-motion, fast-motion, or jump-cut movies (☞ 62) or with Motion Snapshots recorded with **None** selected for **Audio** (☞ 90).
-



Cannot delete images: Remove protection from the files before deletion (☞ 159).

Cannot select photos for printing: The memory card is full (☞ 33) or the photos are in NEF (RAW) format. To print NEF (RAW) photos, transfer the pictures to a computer and use the supplied software or Capture NX 2 (☞ 145).

Pictures are not displayed on TV: The camera is not correctly connected (☞ 148).

Pictures cannot be transferred to a computer: If your system does not meet the requirements on page 143, you may still be able to transfer pictures to the computer using a card reader.

Photos are not displayed in Capture NX 2: Update to the latest version (☞ 223).

Wi-Fi (Wireless Networks)

Smart devices do not display the camera SSID (network name):

- Confirm that camera Wi-Fi is enabled (☞ 120).
- Try turning the smart device Wi-Fi off and then on again.

Miscellaneous

The date of recording is not correct: Set the camera clock (☞ 31, 218).

Menu items are unavailable: Some options are only available at particular settings (☞ 232) or when a memory card is inserted (☞ 24).



Error Messages

This section lists the error messages that appear in the display.

Message	Solution	
(Shutter-speed or aperture display flashes)	If the subject is too bright, lower ISO sensitivity or choose a faster shutter speed or smaller aperture (higher f-number).	71, 72, 73, 201
	If the subject is too dark, raise ISO sensitivity, use a flash, or choose a slower shutter speed or larger aperture (lower f-number).	71, 72, 73, 105, 201
Keeping the zoom ring button pressed, rotate the zoom ring to extend the lens.	A lens with a retractable lens barrel button is attached with the lens barrel retracted. Keeping the retractable lens barrel button pressed, rotate the zoom ring to extend the lens.	28, 256
Check lens. Pictures can only be taken when a lens is attached.	Attach a lens.	27
Lens error. Try again after turning the camera off and on.	Turn the camera off and then on again. If the problem persists or reoccurs frequently, contact a Nikon-authorized service representative.	29
Cannot take pictures. Insert fully-charged battery.	Turn the camera off and recharge the battery or insert a fully charged spare battery.	23, 24
The clock has been reset.	Set the camera clock.	31, 218
No memory card.	Turn the camera off and confirm that the card is correctly inserted.	24



Message	Solution	
This memory card cannot be used. Card may be damaged; insert a different card.	<ul style="list-style-type: none"> • Use an approved card. 	224
	<ul style="list-style-type: none"> • Format the card. If the problem persists, the card may be damaged. Contact a Nikon-authorized service representative. • Insert a new memory card. 	211 24, 224
This memory card is not formatted. Format the memory card?	Select Yes to format the card, or turn the camera off and insert another memory card.	24, 211
Memory card is full.	<ul style="list-style-type: none"> • You may be able to record additional images if you reduce image quality or size. 	171
	<ul style="list-style-type: none"> • Delete unwanted images. • Insert another memory card. 	136 24, 224
Cannot create additional folders on memory card.	If the current folder is numbered 999 and contains either 999 photographs or a photograph numbered 9999, the shutter-release button will be disabled and no further photographs can be taken. Choose Yes for Reset file numbering and then either format the current memory card or insert a new memory card.	218
The movie-record button cannot be used in this mode.	The movie-record button can not be used in best moment capture or Motion Snapshot modes.	79, 90
Photographs cannot be recorded in this mode.	The shutter-release button can not be used to take photographs while a slow-motion movie is being recorded.	64
The capture illuminator has been used consecutively for the maximum time and has turned off.	The capture illuminator on the optional SB-N5 flash unit turns off automatically after extended use. Remove your finger from the shutter-release button for a short period.	111



Message	Solution	
Photographs cannot be taken in shutter-priority auto mode at a shutter speed of "Bulb".	Choose a different shutter speed, or select mode M.	71, 73
Cannot shoot panorama with lens of this focal length.	Use a lens with a focal length of 6 to 30 mm to shoot panoramas. If you are using a zoom lens, choose a focal length between 6 and 30 mm.	54
An error has occurred in the internal circuitry. Try again after turning the camera off and on.	Turn the camera off and then on again. If the problem persists or reoccurs frequently, contact a Nikon-authorized service representative.	—
The camera's internal temperature is high. The camera will now turn off.	Wait for the camera to cool.	xvii
Memory card contains no images.	To view pictures, insert a memory card containing images.	24
Cannot display this file.	The file has been created or modified on a computer or different make of camera, or is corrupt.	—
Check printer.	Check the printer.	—*
Check paper.	Select Resume after loading paper of the correct size.	—*
Paper jam.	Clear the jam and select Resume .	—*
Out of paper.	Insert paper and select Resume .	—*
Check ink supply.	Select Resume after checking the ink.	—*
Out of ink.	Replace the ink and select Resume .	—*

* See the printer manual for more information.



Specifications



Nikon 1 V3 Digital Camera

Type	
Type	Digital camera with support for interchangeable lenses
Lens mount	Nikon 1 mount
Effective angle of view	Approx. 2.7× lens focal length (35 mm format equivalent)
Effective pixels	18.4 million
Image sensor	
Image sensor	13.2 mm × 8.8 mm CMOS sensor (Nikon CX format)
Dust-reduction system	Image sensor cleaning
Storage	
Image size (pixels)	Still images taken in auto, P, S, A, M, best moment capture, and all creative modes other than easy panorama (aspect ratio 3 : 2)
	• 5232 × 3488
	• 3920 × 2616
	• 2608 × 1744
	Still images taken in normal panorama mode with camera panned horizontally (aspect ratio 120 : 23)
	• 4800 × 920
	Still images taken in normal panorama mode with camera panned vertically (aspect ratio 8 : 25)
	• 1536 × 4800
	Still images taken in wide panorama mode with camera panned horizontally (aspect ratio 240 : 23)
	• 9600 × 920
	Still images taken in wide panorama mode with camera panned vertically (aspect ratio 4 : 25)
	• 1536 × 9600
	Still images taken during movie recording (aspect ratio 3 : 2)
• 5232 × 3488 (1080/60p, 1080/30p)	
• 1472 × 984 (720/60p, 720/30p)	
Motion Snapshots (photo portion, aspect ratio 16 : 9)	
• 5232 × 2936	



File format	<ul style="list-style-type: none"> • NEF (RAW): 12-bit, compressed • JPEG: JPEG-Baseline compliant with fine (approx. 1 : 4), normal (approx. 1 : 8) compression • NEF (RAW) + JPEG: Single photograph recorded in both NEF (RAW) and JPEG formats
Picture Control system	Standard, Neutral, Vivid, Monochrome, Portrait, Landscape; selected Picture Control can be modified; storage for custom Picture Controls
Media	microSD (micro Secure Digital), microSDHC, and microSDXC memory cards
File system	DCF 2.0, DPOF, Exif 2.3, PictBridge
Shooting modes	auto; creative, with a choice of the following options: creative palette, HDR, easy panorama, soft, miniature effect, selective color, cross process, and toy camera effect; programmed auto with flexible program, shutter-priority auto, aperture-priority auto, and manual; best moment capture (Active Selection, slow view and Smart Photo Selector); advanced movie (HD movie, slow motion, jump cut, fast motion and 4-second movie), Motion Snapshot
Shutter	
Type	Electronically-controlled vertical-travel focal-plane mechanical shutter; electronic shutter
Speed	<ul style="list-style-type: none"> • Mechanical shutter: $\frac{1}{4000}$–30 s in steps of $\frac{1}{3}$ EV; Bulb; Time (requires optional ML-L3 remote control) • Electronic shutter: $\frac{1}{16,000}$–30 s in steps of $\frac{1}{3}$ EV; Bulb; Time (requires optional ML-L3 remote control) <p>Note: Bulb and Time end automatically after approximately 2 minutes</p>



Flash sync speed	<ul style="list-style-type: none"> • Mechanical shutter: Synchronizes with shutter at $X=1/250$ s or slower • Electronic shutter: Synchronizes with shutter at $X=1/60$ s or slower
Release	
Mode	<ul style="list-style-type: none"> • Single frame, continuous • Self-timer, remote, interval timer shooting
Frame advance rate	Approx. 6, 10, 20, 30, or 60 fps
Self-timer	2 s, 10 s
Remote control modes	Delayed remote (2 s); quick-response remote
Exposure	
Metering	TTL metering using image sensor
Metering method	<ul style="list-style-type: none"> • Matrix • Center-weighted: Meters 4.5 mm circle in center of frame • Spot: Meters 2 mm circle centered on selected focus area
Mode	P programmed auto with flexible program; S shutter-priority auto; A aperture-priority auto; M manual;  scene auto selector
Exposure compensation	-3 – +3 EV in increments of $1/3$ EV
Exposure lock	Luminosity locked at metered value with  (AE-L/AF-L) button
ISO sensitivity (Recommended Exposure Index)	ISO 160; ISO 200–12800 in steps of 1 EV; 6400 (NR); 12800 (NR); auto ISO sensitivity control (ISO 160–6400, 160–3200, 160–800) available (user controlled in P, S, A, and M modes)
Active D-Lighting	On, off



Focus	
Autofocus	Hybrid autofocus (phase-detection/contrast-detect AF); AF-assist illuminator
Lens servo	<ul style="list-style-type: none"> • Autofocus (AF): Single AF (AF-S); continuous AF (AF-C); auto AF-S/AF-C selection (AF-A); full-time AF (AF-F) • Manual focus (MF)
AF-area mode	Single-point, auto-area, subject tracking
Focus area	<ul style="list-style-type: none"> • Single-point AF: 171 focus areas; the center 105 areas support phase-detection AF • Auto-area AF: 41 focus areas
Focus lock	Focus can be locked by pressing shutter-release button halfway (single AF) or by pressing AE-L/AF-L (AE-L/ AF-L) button
Face priority	On, off
Flash	
Built-in flash	Raised by pressing flash button
Guide Number (GN)	Approx. 5/16 (m/ft, ISO 100, 20 °C/68 °F; at ISO 160, Guide Number is approx. 6.3/20.7)
Control	i-TTL flash control using image sensor
Mode	Fill flash, fill flash + slow sync, red-eye reduction, red-eye reduction + slow sync, rear-curtain sync, rear curtain + slow sync
Flash compensation	-3 – +1 EV in increments of $\frac{1}{3}$ EV
Flash-ready indicator	Lights when flash is fully charged
White balance	
	Auto, incandescent, fluorescent, direct sunlight, flash, cloudy, shade, preset manual, all except preset manual with fine tuning



Movie	
Metering	TTL metering using image sensor
Metering method	<ul style="list-style-type: none"> • Matrix • Center-weighted: Meters 4.5 mm circle in center of frame • Spot: Meters 2 mm circle centered on selected focus area
Frame size (pixels)/ recording rate	HD movies (aspect ratio 16 : 9)
	<ul style="list-style-type: none"> • 1920 × 1080/60p (59.94 fps) • 1920 × 1080/30p (29.97 fps) • 1280 × 720/60p (59.94 fps) • 1280 × 720/30p (29.97 fps)
	Slow-motion movies
	<ul style="list-style-type: none"> • 1280 × 720/120 fps (aspect ratio 16 : 9; plays at 30p/29.97 fps) • 768 × 288/400 fps (aspect ratio 8 : 3; plays at 30p/29.97 fps) • 416 × 144/1200 fps (aspect ratio 26 : 9; plays at 30p/29.97 fps)
	Fast-motion, jump-cut, and 4-second movies (aspect ratio 16 : 9)
	1920 × 1080/30p (29.97 fps)
	Motion Snapshots (movie portion, aspect ratio 16 : 9)
	1920 × 1080/60p (59.94 fps) (plays at 24p/23.976 fps)
File format	MOV
Video compression	H.264/MPEG-4 Advanced Video Coding
Audio recording format	PCM
Audio recording device	Built-in or optional external ME-1 stereo microphone; sensitivity adjustable
Monitor	7.5 cm (3-in.), approx. 1037k-dot, TFT vari-angle LCD touch screen with brightness and angle adjustment
Playback	Full-frame and thumbnail (4, 9, or 16 images or calendar) playback with playback zoom, movie and panorama playback, slide show, histogram display, auto image rotation, and rating option



Interface	
USB	Hi-Speed USB
HDMI output	Type D HDMI connector
Multi accessory port	Used for designated accessories
Audio input	Stereo mini-pin jack (3.5mm diameter)
Wireless	
Standards	IEEE 802.11b, IEEE 802.11g
Communications protocols	<ul style="list-style-type: none"> • IEEE 802.11b: DSSS/CCK • IEEE 802.11g: OFDM
Operating frequency	2412–2462 MHz (channels 1–11)
Range (line of sight)	Approximately 10 m/33 ft (assumes no interference; range may vary with signal strength and presence or absence of obstacles)
Data rate	54 Mbps Maximum logical data rates according to IEEE standard. Actual rates may differ.
Security	<ul style="list-style-type: none"> • Authentication: Open system, WPA2-PSK • Encryption: AES
Wireless setup	Supports WPS
Access protocols	Infrastructure
Supported languages	
	Arabic, Bengali, Bulgarian, Chinese (Simplified and Traditional), Czech, Danish, Dutch, English, Finnish, French, German, Greek, Hindi, Hungarian, Indonesian, Italian, Japanese, Korean, Marathi, Norwegian, Persian, Polish, Portuguese (European and Brazilian), Romanian, Russian, Serbian, Spanish, Swedish, Tamil, Telugu, Thai, Turkish, Ukrainian, Vietnamese
Power source	
Battery	One rechargeable Li-ion EN-EL20a battery
AC adapter	EH-5b AC adapter; requires EP-5C power connector (available separately)
Tripod socket	
	1/4-in. (ISO 1222)



Dimensions/weight	
Dimensions (W × H × D)	Approx. 110.9 × 65.0 × 33.2 mm (4.4 × 2.6 × 1.3 in.), excluding projections
Weight	Approx. 324 g (11.4 oz) with battery and memory card but without body cap; approx. 282 g (9.9 oz), camera body only

Operating environment	
Temperature	0 °C–40 °C (+32 °F–104 °F)
Humidity	85% or less (no condensation)

- Unless otherwise stated, all figures are for a camera with a fully-charged battery operating at the temperature specified by the Camera and Imaging Products Association (CIPA): 23 ±3 °C (73.4 ±5.4 °F).
- Nikon reserves the right to change the specifications of the hardware and software described in this manual at any time and without prior notice. Nikon will not be held liable for damages that may result from any mistakes that this manual may contain.

MH-29 battery charger	
Rated input	AC 100–240 V, 50–60 Hz, 0.2 A
Rated output	DC 8.4 V/0.6 A
Supported batteries	Nikon EN-EL20a rechargeable Li-ion batteries
Charging time	Approx. 3 hours at an ambient temperature of 25 °C (77 °F) when no charge remains
Operating temperature	0 °C–40 °C (+32 °F–104 °F)
Dimensions (W × H × D)	Approx. 67.0 × 28.0 × 94.0 mm (2.6 × 1.1 × 3.7 in.), excluding plug adapter
Weight	Approx. 83 g (2.9 oz), excluding plug adapter

EN-EL20a rechargeable Li-ion battery	
Type	Rechargeable lithium-ion battery
Rated capacity	7.2 V, 1110 mAh
Operating temperature	0 °C–40 °C (+32 °F–104 °F)
Dimensions (W × H × D)	Approx. 30.7 × 50.0 × 14.0 mm (1.2 × 2.0 × 0.6 in.)
Weight	Approx. 42 g (1.5 oz), excluding terminal cover



1 NIKKOR VR 10–30mm f/3.5–5.6 PD-ZOOM

Type	1 mount lens
Focal length	10–30 mm
Maximum aperture	f/3.5–5.6
Construction	9 elements in 7 groups (including 4 aspherical lens elements, 1 ED lens element, and HRI lens elements)
Angle of view	77°–29° 40'
Vibration reduction	Lens shift using voice coil motors (VCMs)
Minimum focus distance	0.2 m (0.7 ft) from focal plane at all zoom positions
Diaphragm blades	7 (rounded diaphragm opening)
Diaphragm	Fully automatic
Aperture range	• 10 mm focal length: f/3.5–16 • 30 mm focal length: f/5.6–16
Dimensions	Approx. 58 mm diameter × 28 mm (distance from camera lens mount flange when lens is retracted)
Weight	Approx. 85 g (3.0 oz)

1 NIKKOR 11–27.5mm f/3.5–5.6

Type	1 mount lens
Focal length	11–27.5 mm
Maximum aperture	f/3.5–5.6
Construction	8 elements in 6 groups (including 1 ED lens element and 1 aspherical lens element), 1 protective glass element
Angle of view	72°–32° 20'
Minimum focus distance	0.3 m (1.0 ft) from focal plane at all zoom positions
Diaphragm blades	7 (rounded diaphragm opening)
Diaphragm	Fully automatic
Aperture range	• 11 mm focal length: f/3.5–16 • 27.5 mm focal length: f/5.6–16
Filter-attachment size	40.5 mm (P=0.5 mm)
Dimensions	Approx. 57.5 mm diameter × 31 mm (distance from camera lens mount flange when lens is retracted)
Weight	Approx. 83 g (3.0 oz)



DF-N1000 Electronic Viewfinder	
Type	0.48-in., approx. 2359k-dot color TFT LCD viewfinder with diopter control and brightness adjustment
Frame coverage	Approx. 100% horizontal and 100% vertical
Eyepoint	16 mm (-1.0 m^{-1} ; from viewfinder eyepiece protective glass)
Diopter adjustment	-3 – $+1 \text{ m}^{-1}$
Eye sensor	Camera switches to viewfinder display when it detects that viewfinder is in use
Operating temperature	0 °C–40 °C (+32 °F–104 °F)
Dimensions (W × H × D)	Approx. 32.5 × 33.7 × 40.8 mm (1.3 × 1.3 × 1.6 in.), excluding projections
Weight	Approx. 26 g (0.9 oz), excluding connector cover
GR-N1010 Grip	
Operating temperature	0 °C–40 °C (+32 °F–104 °F)
Dimensions (W × H × D)	Approx. 119.2 × 76.6 × 48.8 mm (4.7 × 3.0 × 1.9 in.), excluding projections
Weight	Approx. 63 g (2.2 oz), excluding connector cap

Specifications subject to change without notice. Nikon will not be held liable for damages that may result from any mistakes that this manual may contain.



■ 1 NIKKOR Lenses
1 NIKKOR VR 10–30mm f/3.5–5.6 PD-ZOOM

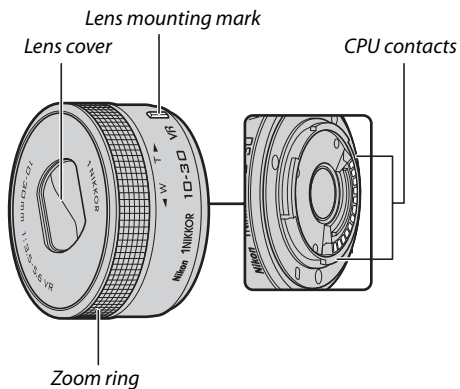

1 NIKKOR 11–27.5mm f/3.5–5.6

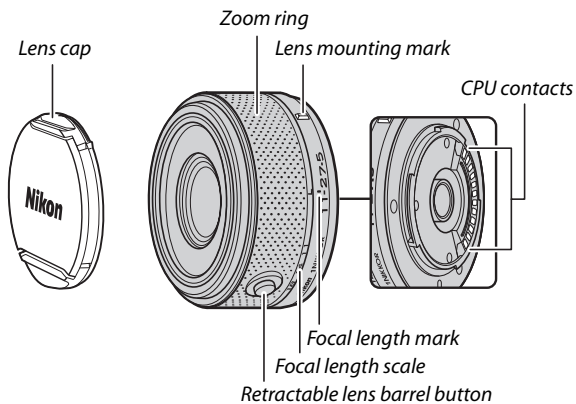

1 NIKKOR lenses are exclusively for Nikon 1 interchangeable lens format digital cameras. The angle of view is equivalent to a 35 mm format lens with a focal length about 2.7× longer. The 1 NIKKOR VR 10–30mm f/3.5–5.6 PD-ZOOM supports vibration reduction, which can be adjusted using the **Optical VR** option in the camera menus (📖 183).

Use the zoom ring to zoom in and out (📖 45).

Lens Care

- Keep the CPU contacts clean.
- Use a blower to remove dust and lint from the lens surfaces. To remove smudges and fingerprints, apply a small amount of ethanol or lens cleaner to a soft, clean cotton cloth or lens-cleaning tissue and clean from the center outwards using a circular motion, taking care not to leave smears or touch the glass with your fingers.
- Never use organic solvents such as paint thinner or benzene to clean the lens.
- A lens hood or NC filter can be used to protect the front lens element. When using an optional lens hood, do not pick up or hold the lens or camera using only the hood. Lens hoods and filters are not available for the 1 NIKKOR VR 10–30mm f/3.5–5.6 PD-ZOOM.
- When the lens is not in use, attach the rear cap and either ensure that the lens is retracted and the cover closed (1 NIKKOR VR 10–30mm f/3.5–5.6 PD-ZOOM) or attach the front cap (other lenses).
- If the lens will not be used for an extended period, store it in a cool, dry location to prevent mold and rust. Do not store in direct sunlight or with naphtha or camphor moth balls.
- Keep the lens dry. Rusting of the internal mechanism can cause irreparable damage.
- Leaving the lens in extremely hot locations could damage or warp parts made from reinforced plastic.
- When using the 1 NIKKOR VR 10–30mm f/3.5–5.6 PD-ZOOM, be sure not touch the lens cover. Failure to observe this precaution could result in product malfunction.



Supplied Accessories

- 40.5 mm snap-on Front Lens Cap LC-N40.5 (for use with the 1 NIKKOR 11–27.5mm f/3.5–5.6)
- Rear Lens Cap LF-N1000

Optional Accessories

- 40.5 mm screw-on filters (for use with the 1 NIKKOR 11–27.5mm f/3.5–5.6)
- 40.5 mm screw-on Hood HN-N102 (for use with the 1 NIKKOR 11–27.5mm f/3.5–5.6; attaches as shown below)

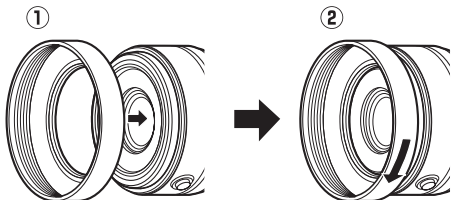

■ The Optional FT1 Mount Adapter

Read this section for information on using the optional FT1 mount adapter. Before proceeding, be sure that you have read and understood this manual and the documentation for the FT1 and lenses.

Autofocus

Autofocus is available only with AF-S lenses; other lenses support manual focus only. Set the camera focus mode to **AF-S** or **AF-C**. The only AF-area mode available is **Single-point** and the camera focuses on the subject in the center focus area only. Face priority is not supported. In some cases, a beep may sound, the in-focus indicator may be displayed, and pictures can be taken when the camera is not in focus; if this occurs, focus manually.

Manual Focus

Follow the steps below to focus manually when using the FT1 with a NIKKOR F mount lens.

1 Select manual focus.

Press **▲** (AF) to display focus mode options, then highlight **MF** and press **OK**.

2 Focus.

Rotate the lens focus ring until the subject is in focus.

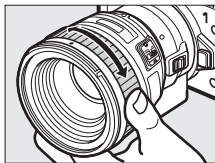

If **AF-S** or **AF-C** is selected for **Focus mode** and the lens supports autofocus with manual override, you can focus using autofocus and then keep the shutter-release button pressed halfway and rotate the lens focus ring to fine-tune focus manually. To refocus using autofocus, press the shutter-release button halfway again.

To zoom in on the display for more precise focus, press  (note that this feature is not available during movie recording or in slow-motion movie mode). A navigation window will appear in a gray frame at the bottom right of the display.

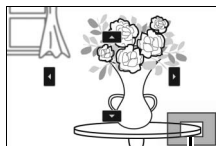

Navigation window

Rotate the main command dial to choose from magnifications of up to about 10× and use the multi selector to scroll to areas of the frame not visible in the display. To exit zoom, press .

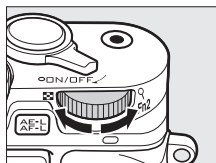

Main command dial



The Electronic Rangefinder

If a CPU lens is attached in manual focus mode, the focus indicator can be used to check whether the camera is focused on the subject in the center focus area.

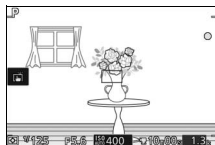

Focus indicator	Status
●	In focus.
▶	Camera focused in front of subject.
◀	Camera focused behind subject.
▶ ◀ (flashes)	Unable to determine focus.

Note that with some subjects, the in-focus indicator (●) may be displayed when the camera is not in focus. Check focus in the display before shooting.

Error Messages and Displays

The following warnings appear in the camera aperture display.

Display	Problem	Solution
FEE	Lens aperture ring is not locked at minimum aperture.	When using CPU lenses, lock aperture ring at minimum aperture (highest f-number).
F---	Non-CPU lens is attached, or no lens is attached.	When using non-CPU lens, rotate lens aperture ring to adjust aperture.



Restrictions

- Auto and best moment capture modes are not supported.
- Motion Snapshots can be recorded only when an AF-S lens is attached and the camera is in autofocus mode and then only when the subject is in focus. Do not attempt to adjust focus using the focus ring.
- Shutter speeds of 1 s or slower are not available.
- The sound monitor switch and focus operation button (Focus Lock/MEMORY RECALL/AF Start) have no effect.

Precautions for Use

- Lenses over 380 g (13.4 oz) should be supported at all times. Do not hold the camera or carry the camera by the strap without supporting the lens. Failure to observe this precaution could damage the camera lens mount.
- Lines may appear in photographs taken with non-CPU lenses stopped down to minimum aperture.
- During movie recording, select exposure mode A or M to prevent sounds made by the lens being picked up by the microphone.
- During continuous shooting, focus is fixed at the position for the first shot in each burst. Frame rates may slow when  is selected in continuous mode.
- Certain lenses will block the AF-assist illuminator and, at some distances, the flash.
- The tops and bottoms may be missing from circular *bokeh* shapes created at wide apertures using lenses with a maximum aperture of f/1.4.



■ Supported Standards

- **DCF Version 2.0:** The Design Rule for Camera File Systems (DCF) is a standard widely used in the digital camera industry to ensure compatibility among different makes of camera.
- **DPOF:** Digital Print Order Format (DPOF) is an industry-wide standard that allows pictures to be printed from print orders stored on the memory card.
- **Exif version 2.3:** The camera supports Exif (Exchangeable Image File Format for Digital Still Cameras) version 2.3, a standard in which information stored with photographs is used for optimal color reproduction when the images are output on Exif-compliant printers.
- **PictBridge:** A standard developed through cooperation with the digital camera and printer industries, allowing photographs to be output directly to a printer without first transferring them to a computer.
- **HDMI:** High-Definition Multimedia Interface is a standard for multimedia interfaces used in consumer electronics and AV devices capable of transmitting audiovisual data and control signals to HDMI-compliant devices via a single cable connection.



Trademark Information

Mac and OS X are registered trademarks of Apple Inc. in the United States and/or other countries. Microsoft, Windows, and Windows Vista are either registered trademarks, or trademarks of Microsoft Corporation in the United States and/or other countries. The PictBridge logo is a trademark. The microSD, microSDHC, and microSDXC logos are trademarks of SD-3C, LLC. HDMI, the HDMI logo and High-Definition Multimedia Interface are trademarks or registered trademarks of HDMI Licensing LLC.

HDMI

Wi-Fi and the Wi-Fi logo are trademarks or registered trademarks of the Wi-Fi Alliance. All other trade names mentioned in this manual or the other documentation provided with your Nikon product are trademarks or registered trademarks of their respective holders.

FreeType License (FreeType2)

Portions of this software are copyright © 2012 The FreeType Project (<http://www.freetype.org>). All rights reserved.

MIT License (HarfBuzz)

Portions of this software are copyright © 2014 The HarfBuzz Project (<http://www.freedesktop.org/wiki/Software/HarfBuzz>). All rights reserved.



Battery Life

The number of shots or movie footage that can be recorded with fully-charged batteries varies with the condition of the battery, temperature, the interval between shots, and the length of time menus are displayed. Sample figures for EN-EL20a (1110 mAh) batteries are given below.

- **Still images: Approximately 310 shots**
- **Movies: Approximately 75 minutes at 1080/60p**

Measured according to CIPA standards at 23 ± 3 °C (73.4 ± 5.4 °F) with the camera at default settings, a fully-charged battery, a 1 NIKKOR VR 10-30mm f/3.5-5.6 PD-ZOOM lens, and a 16GB SanDisk SDSDQXP-016G-J35 UHS-I microSDHC card. Value for still images obtained under the following test conditions: photographs taken at intervals of 30 s with the built-in flash fired with every other shot and the camera turned off and then on after every ten shots. Value for movies obtained under the following test conditions: a series of 10 minute movies with a file size of up to 4 GB were recorded; recording was only interrupted when temperature warning was displayed.

The following can reduce battery life:

- Keeping the shutter-release button pressed halfway
- Repeated autofocus operations
- Taking NEF (RAW) photographs
- Slow shutter speeds
- Using Wi-Fi
- Using vibration reduction mode with VR lenses
- Using zoom with power zoom lenses
- Using viewfinders, grips, flash units, or GPS units

To ensure that you get the most from rechargeable Nikon EN-EL20a batteries:

- Keep the battery contacts clean. Soiled contacts can reduce battery performance.
- Use batteries immediately after charging. Batteries will lose their charge if left unused.



Index

Symbols

(Auto mode)	8, 38
P (Programmed auto)	70, 170
S (Shutter-priority auto)	71, 170
A (Aperture-priority auto)	72, 170
M (Manual)	73, 170
(Creative mode)	8, 49
(Advanced movie mode)	8, 59, 62
(Best moment capture mode)	8, 76
(Motion Snapshot mode)	8, 87
(Creative Palette)	50, 52
(HDR)	50, 53
(Easy panorama)	50, 54
(Soft)	50
(Miniature effect)	50
(Selective color)	50, 57
(Cross process)	50, 58
(Toy camera effect)	50, 177
(Scene auto selector)	170
(Portrait)	44
(Landscape)	44
(Night portrait)	44
(Close up)	44
(Night landscape)	44
(Auto)	44
(flexible program)	70
MENU (menu) button	10, 156, 167, 189, 195, 209
(playback) button	41, 85, 91
(delete) button	43, 67, 86, 91, 136
DISP (display) button	6
(OK) button	9
(feature)	12
(AE-L/AF-L)	214, 216
(continuous shooting/self-timer)	92, 94, 96
(single frame)	93
(continuous)	92

(self-timer)	94
(remote control)	96
AF (focus mode)	99
(exposure compensation)	104
(flash mode)	106
(red-eye reduction)	106
SLOW (slow sync)	106
REAR (rear-curtain sync)	106
(flash-ready indicator)	107, 110
PRE (Preset manual)	198
(matrix)	177
(center-weighted)	177
(spot)	177
(auto-area)	185
(single-point)	185
(subject tracking)	185

Numerics

4-second movie	62
----------------------	----

A

AC adapter	222, 225
Accessories	221
Active D-Lighting	179
Active Selection	76, 174
Adobe RGB	178
Advanced movie mode	8, 59, 62
AE lock	214
AF	99, 185
AF-A	99
AF-area mode	185
AF-assist illuminator	186
AF-C	99
AF-F	99
AF-S	99
Aperture	72, 73
Aperture-priority auto	72, 170
Assign AE/AF-L button	214
Assign Fn buttons	14
Assisted GPS	115
Attaching the lens	27



Audio	90
Auto distortion control	178
Auto image capture	194
Auto image rotation	219
Auto mode	38
Auto photography	194
Auto power off	29, 114, 213
Auto-area (AF-area mode)	185
Autofocus	99, 185
Automatic scene selection	44
Auto-select AF	99
Available settings	232

B

Battery	23, 24, 33, 253
Beep	39, 95, 212
Best moment capture mode	76
Best shot	82, 85
Body cap	2, 223
Border	151
Bounce lighting	111
Brightness	204
Buffering	78, 83, 84, 88
Built-in AF assist	186
Built-in flash	105
Bulb	74

C

Calendar	134, 138
Calendar playback	134
Capture 40 frames over	174
Capture illuminator	111
Capture NX 2	173, 207, 223
CEC	149
Center-weighted (Metering)	177
Charging a battery	23
Clock	31, 32, 114, 218
Clock battery	32
Close up	44
Color space	178
Color temperature	200
Combine 4-second movies	165
Combine NMS movies	166

Command dial	41, 70–73, 102
Compatible lens	221
Computer	141
Continuous	92
Continuous AF	99
Contrast	179, 204
Creative mode	49
Creative Palette	50, 52
Crop	162
Crop (PictBridge)	151
Cross process	50, 58
Custom Picture Control	203, 206

D

Date and time	31, 218
Date format	31, 218
Daylight saving time	31, 218
DCF version 2.0	263
Defaults	235
Delete	43, 67, 86, 91, 136
Delete all images	136
Delete selected images	136
Detailed display	5, 6
Detailed photo information	7, 130
Digital Print Order Format	155, 263
Diopter adjustment control	35
Display	6, 211
Display brightness	211
D-Lighting	160
DPOF	153, 155, 263
DPOF print order	153, 155
Dust shield	227, 228

E

Easy panorama	50, 54
Edit movie	163
Electronic viewfinder	34, 212, 221
Electronic VR	184
Exif version 2.3	263
Exposure	104, 170, 177, 214
Exposure compensation	104
Exposure indicator	74
Exposure lock	214



Exposure mode	170
Eye sensor	34

F

Face priority	45, 169
Fast motion	62
File format	176
Fill flash	106
Filter effects	204, 205
Filter strength	176
Fine-tuning white balance	197
Firmware version	210
Flash	105, 109, 187, 188
Flash compensation	188
Flash control	187
Flash mode	106
Flash range	108
Flash units	109, 222
Flash-ready indicator	107, 110
Flexible program	70
Flicker reduction	217
Fn button	14
Focal length	130
Focal length scale	256
Focal plane mark	2, 103
Focus	99, 185
Focus area	39, 185
Focus lock	216
Focus mode	99
Focusing the viewfinder	35
Format memory card	26, 211
Frame rate	129, 191, 192
Frame size/frame rate	192
Frames saved (default)	174
FT1	259
Full-frame playback	41, 129
Full-time AF	99

G

GP-N100	113
GPS	113
Grid display	40
Grip	36, 221

H

H.264	251
HD movie	62, 192
HDMI	148, 263
HDMI device control	149
HDMI-CEC	149
HDR	53
High definition	148, 263
High ISO noise reduction	208
Histogram	132
Hue	204
Hue (Cross process)	58

I

Image processing menu	195
Image quality	171
Image review	159
Image selection	158
Image size	172
Index print	153
Infrared receiver	2, 97
Interval timer shooting	181
ISO sensitivity	201

J

JPEG	171
Jump cut	62

L

Landscape	44, 202
Language	30, 210
Lens	27, 45, 183, 221, 254
Lens cap	27, 256
Lens mount	103
Live image control	47
Load from/save to card	207
Location data	114
Long exposure NR	180

M

Manual	73, 170
Manual focus	102
Matrix (Metering)	177



Max. shots per minute	194
Maximum aperture	254
Memory card .. 24, 26, 211, 224, 236	
Memory card access lamp	40
Memory card capacity	236
Metering	177
Microphone	60, 193
microSD card	224
Miniature effect	50
Mode dial	8
Monitor	5, 6, 15, 211
Monochrome	202
Motion Snapshot mode	87
Mount adapter	221, 259
MOV	173, 176, 238
Movie before/after	175
Movie menu	189
Movie sound options	193
Movie-record button	60
Movies	59, 62, 192
Multi accessory port	35, 109, 113
Multi selector	9

N

NEF (RAW)	171, 173
Network connection	119
Neutral	202
Night landscape	44
Night portrait	44
Nikon Transfer 2	146
NMS	173, 176, 238
Normal panorama	172, 237
Number of copies (PictBridge) ..	151
Number of shots saved	175

O

On release, record	174
Optical VR	183
Optional flash	109, 222

P

Page size (PictBridge)	151
Photo information	7, 129

PictBridge	150, 263
Picture Control	202, 206
PIN-entry WPS	122
Pixel mapping	220
Playback	41, 129
Playback highlight display	212
Playback menu	156
Playback zoom	135
Portrait	44, 202
Portrait (Soft)	176
Power connector	222, 225
Power drive zoom	45
Power switch	29
Preset manual	196, 198
Press the shutter-release button all the way down	40, 44
Press the shutter-release button halfway	39, 44
Print border (PictBridge)	151
Print date	155
Print DPOF print order	153
Print time stamp (PictBridge)	151
Printing	150
Programmed auto	70, 170
Protect	159
Push-button WPS	121

Q

Quick adjust	204
--------------------	-----

R

Rating	137, 160
Rear-curtain sync	106
Red-eye reduction	106
Remote control	96, 213
Remote on duration	213
Removing the lens from the camera 28	
Reset file numbering	218
Reset movie options	189
Reset processing options	195
Reset setup options	209
Reset shooting options	167



Reset Wi-Fi settings	124
Resize	161
Retractable lens barrel button	28, 29, 256
Rotate tall	159

S

Saturation	204
Saturation (Toy camera effect) ...	177
Scene auto selector	170
Scene selection	44
Select by date	153
Select color	57
Select images by date	136
Select images for printing	153
Selective color	50, 57
Self-timer	94
Sensitivity	201
Set clock from satellite	114
Setup menu	209
Sharpening	204
Shooting menu	167
Shutter button AE lock	210
Shutter speed	71, 73
Shutter-priority auto	71, 170
Shutter-release button	39, 44
Silent photography	212
Simple photo info	7, 129
Simplified display	6
Single AF	99
Single frame	93
Single-point	185
Size	161, 172, 192, 247, 251
Slide show	138
Slot empty release lock	211
Slow motion	62, 191
Slow sync	106
Slow view	80
Smart Photo Selector	82
Soft	50, 176
Sound settings	212
Speaker	3, 66

Speedlight	109, 222
Spot (Metering)	177
sRGB	178
SSID	123
Standard	202
Start printing (PictBridge)	152
Strap	23
Subject tracking	185
System requirements	143

T

Tap shooting options	116
Television	148
Temperature warnings	xvii
Thumbnail playback	133
Time	31, 74, 218
Time stamp	151
Time zone	218
Time zone and date	218
Timer	94, 181
Toning	204, 205
Touch screen	17, 116, 209
Toy camera effect	50, 177
Trimming movies	163

U

USB	145, 150
USB cable	145, 150
UTC	114

V

Vari-angle monitor	3, 15
View SSID	123
Viewfinder	35, 212, 221
ViewNX 2	141
Vignetting	177
Virtual horizon	7
Vivid	202
Volume	65, 140
VR	183, 184

W

White balance	196
---------------------	-----



Wide panorama	172, 237
Wi-Fi	xix, 119
Wi-Fi upload	125
Wind noise reduction	193
Wireless	xix, 119
Wireless Mobile Utility	119, 120

Z

Zoom guide	45
Zoom ring	28, 45, 256



No reproduction in any form of this manual, in whole or in part (except for brief quotation in critical articles or reviews), may be made without written authorization from NIKON CORPORATION.

NIKON CORPORATION

© 2014 Nikon Corporation



SB4B01(11)
6MVA7611-01